



# Fitzpatrick Woolmer

## Recycled Plastic Bowman™ Option A

Our recycled plastic Option A **Bowman™** information displays offer a highly visible, durable solution, perfect for country parks and nature reserves. Made from 100% recycled UK plastic waste, they offer an eco-friendly information display solution that requires minimal maintenance and will never rot or degrade.

These displays welcome visitors, provide essential wayfinding, and convey your unique brand message at the point of arrival. This ensures a smooth and engaging start to the visitor journey, enhancing the overall experience and creating a lasting first impression.

### Product features

- \* Wood effect recycled plastic construction
- \* 100% recyclable
- \* No maintenance required
- \* Tamper resistant fixings
- \* Removable graphic panel
- \* Cedar effect finish
- \* Standard sizes A2, A1 and A0
- \* 1 year manufacturer's warranty

Fitzpatrick Woolmer Design & Publishing Limited

Unit 7 Lakeside Park, Neptune Close, Rochester, Kent, ME2 4LT  
t: 01634 711 771 e: info@fwdp.co.uk w: fwdp.co.uk



By Appointment to His Majesty The King  
Manufacturer of Signs and Wayfinding  
Fitzpatrick Woolmer Design & Publishing Ltd, Kent

Specification applies to the standard product. Our range of options usually allow us to accommodate any differences you may require. Please contact us and we will be happy to support you in developing this specification to meet your requirements.

Option delete/ update as appropriate

**Manufacturer:** Fitzpatrick Woolmer,  
Unit 7 Lakeside Park, Neptune Close,  
Rochester, Kent, ME2 4LT.  
Tel: 01634 711 771  
Email: info@fwdp.co.uk

**Frame Material:** Polystyrene foam

**Origin:** UK

**Certification:** 100% recycled plastic waste

**Posts Material:** Stainless steel - 304 Grade

**Frame Finish:** Cedar effect

**Posts Colour:** RAL 9005 Black

**Visible fixings:** Stainless steel security fixings to removable parts

**Capacity:** Will accommodate a 3mm thick printed graphic panel

**Weight:** 55kg

**Installation:** Posts extend 600mm below ground level

**Guarantee:** One year manufacturer's warranty

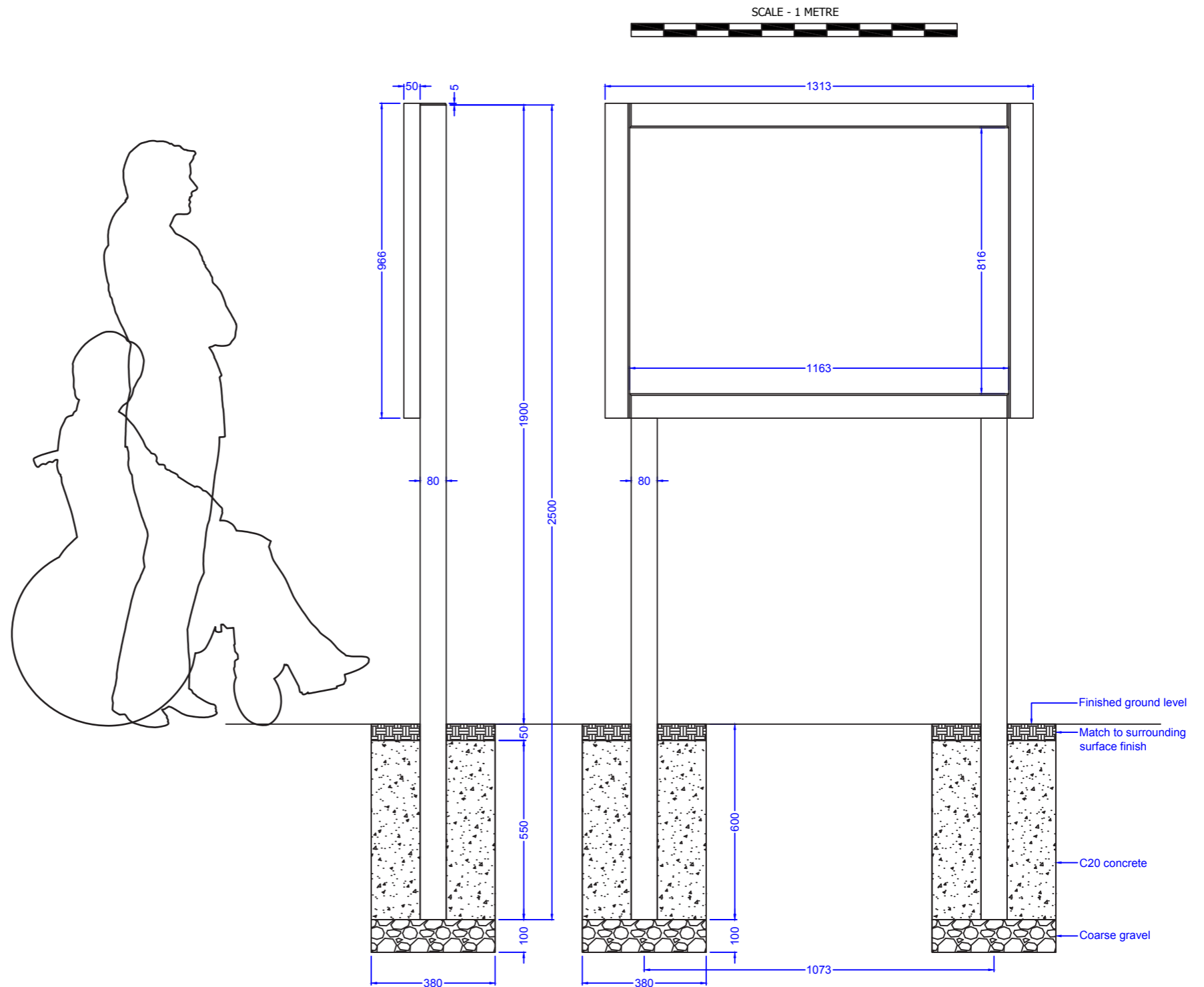
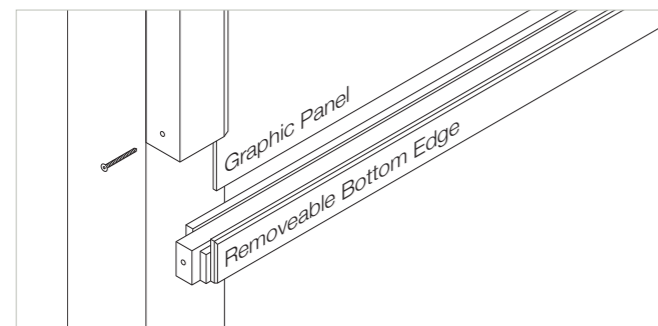

Note: All dimensions are indicative only. Footing details are subject to soil conditions and structural engineers recommendations.

Specification applies to the standard product. Our range of options usually allow us to accommodate any differences you may require. Please contact us and we will be happy to support you in developing this specification to meet your requirements.

Option delete/ update as appropriate

**Manufacturer:** Fitzpatrick Woolmer,  
Unit 7 Lakeside Park, Neptune Close,  
Rochester, Kent, ME2 4LT.  
Tel: 01634 711 771  
Email: info@fwdp.co.uk

**Frame Material:** Polystyrene foam

**Origin:** UK

**Certification:** 100% recycled plastic waste

**Posts Material:** Stainless steel - 304 Grade

**Frame Finish:** Cedar effect

**Posts Colour:** RAL 9005 Black

**Visible fixings:** Stainless steel security fixings to removable parts

**Capacity:** Will accommodate a 3mm thick printed graphic panel

**Weight:** 42kg

**Installation:** Posts extend 600mm below ground level

**Guarantee:** One year manufacturer's warranty

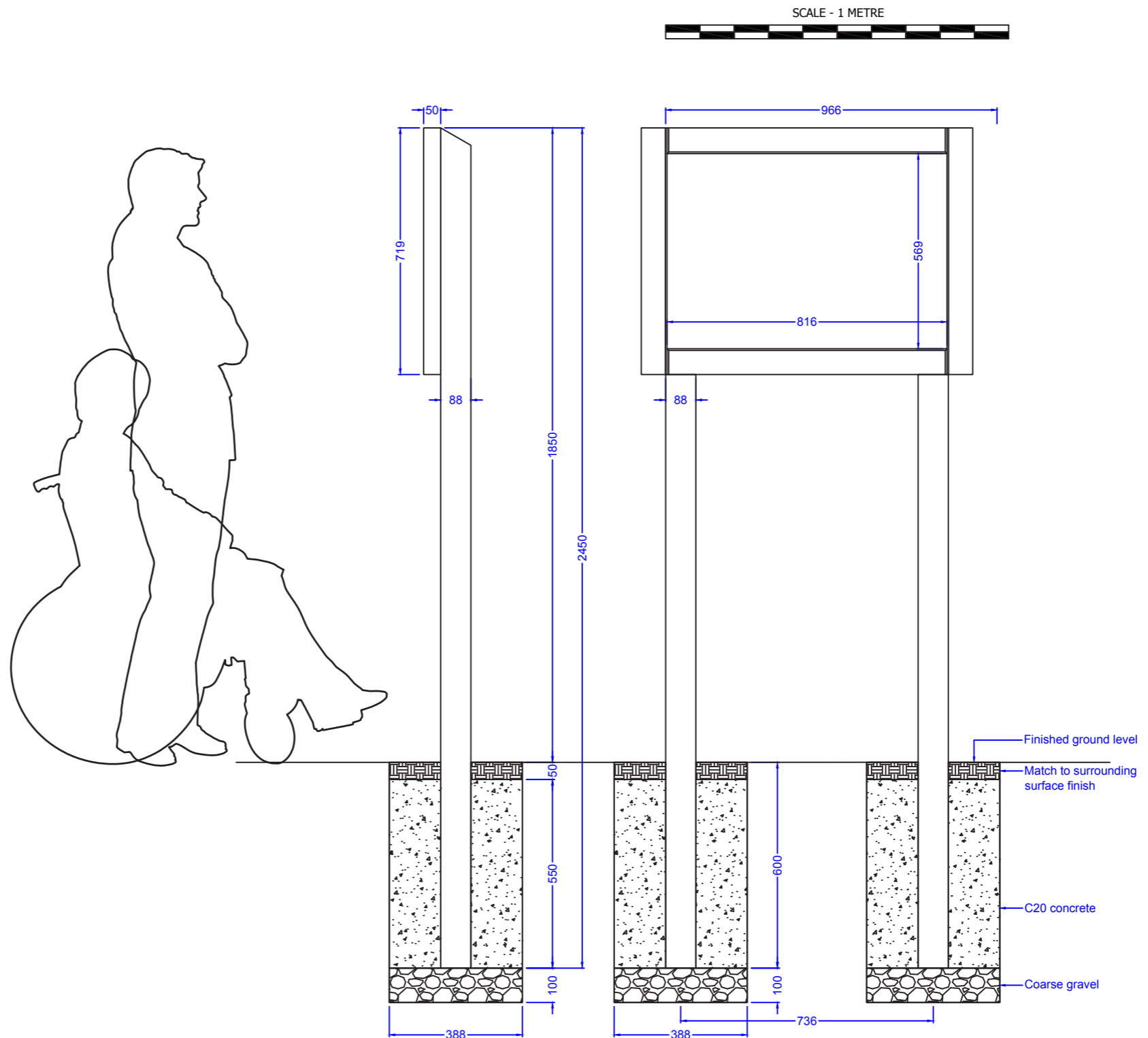
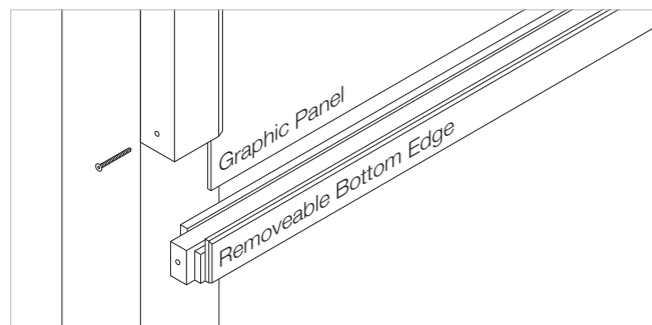

Note: All dimensions are indicative only. Footing details are subject to soil conditions and structural engineers recommendations.

Specification applies to the standard product. Our range of options usually allow us to accommodate any differences you may require. Please contact us and we will be happy to support you in developing this specification to meet your requirements.

Option delete/ update as appropriate

**Manufacturer:** Fitzpatrick Woolmer,  
Unit 7 Lakeside Park, Neptune Close,  
Rochester, Kent, ME2 4LT.  
Tel: 01634 711 771  
Email: info@fwdp.co.uk

**Frame Material:** Polystyrene foam

**Origin:** UK

**Certification:** 100% recycled plastic waste

**Posts Material:** Stainless steel - 304 Grade

**Frame Finish:** Cedar effect

**Posts Colour:** RAL 9005 Black

**Visible fixings:** Stainless steel security fixings to removable parts

**Capacity:** Will accommodate a 3mm thick printed graphic panel

**Weight:** 35kg

**Installation:** Posts extend 600mm below ground level

**Guarantee:** One year manufacturer's warranty

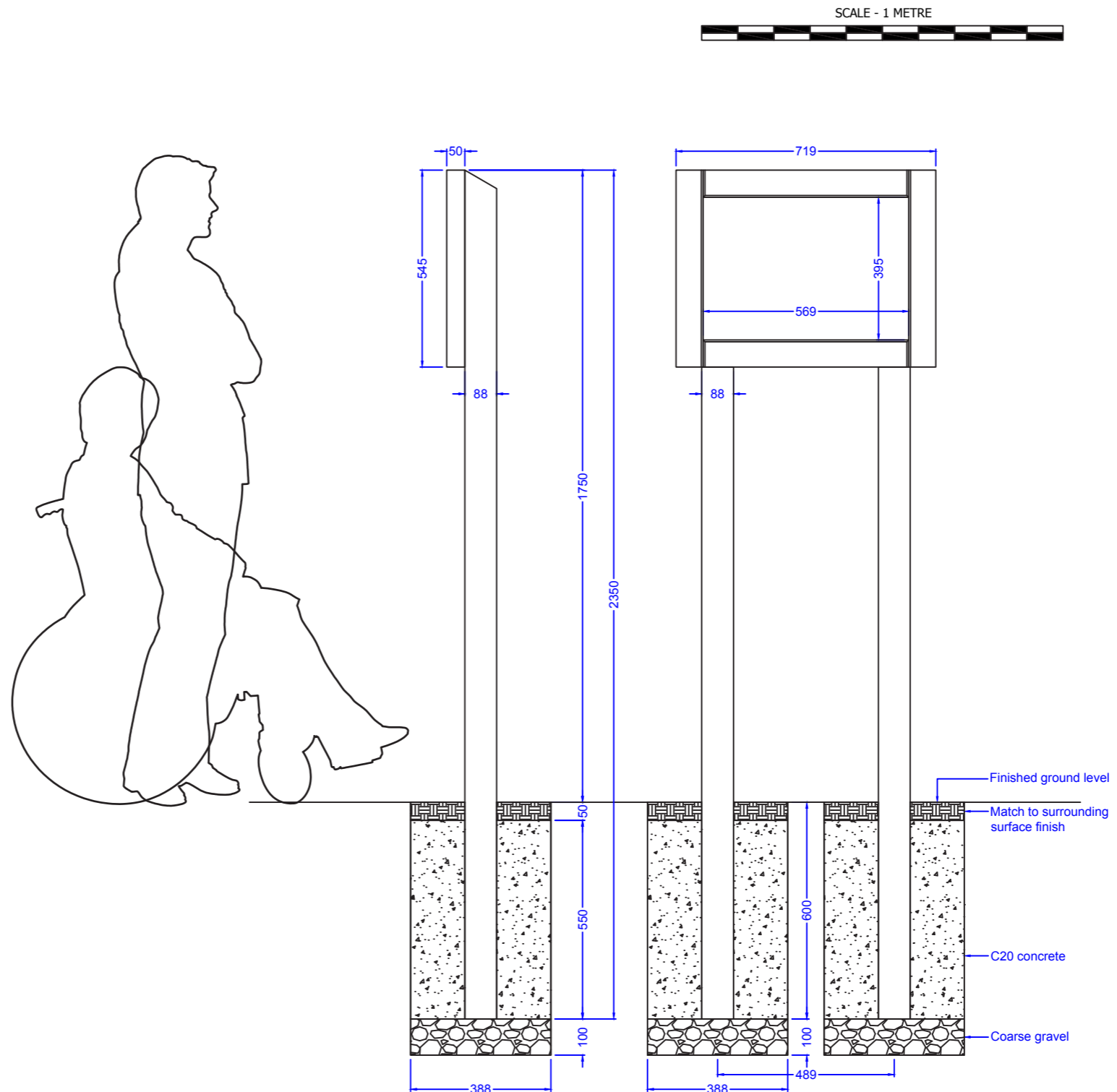
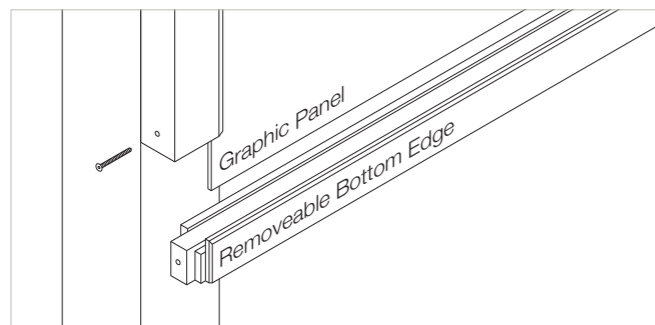

Note: All dimensions are indicative only. Footing details are subject to soil conditions and structural engineers recommendations.