



Fitzpatrick Woolmer

Recycled Plastic Bowman™ Option B

Our recycled plastic Option B **Bowman™** information displays provide a highly visible, durable solution ideal for country parks, nature reserves, and woodland trails. Made from 100% recycled UK plastic waste, they offer an eco-friendly information display solution that requires minimal maintenance and will never rot or degrade.

These displays effectively welcome visitors, guide them with wayfinding information, and share unique facts about the site's natural history and heritage. They enhance the visitor experience by offering both practical and educational insights at key points along their journey.

Product features

- * Wood effect recycled plastic construction
- * 100% recyclable
- * No maintenance required
- * Tamper resistant fixings
- * Removable graphic panel
- * Cedar effect finish
- * Standard sizes A2 and A1
- * 1 year manufacturer's warranty

Fitzpatrick Woolmer Design & Publishing Limited

Unit 7 Lakeside Park, Neptune Close, Rochester, Kent, ME2 4LT
 t: 01634 711 771 e: info@fwdp.co.uk w: fwdp.co.uk



By Appointment to His Majesty The King
 Manufacturer of Signs and Wayfinding
 Fitzpatrick Woolmer Design & Publishing Ltd, Kent

Specification applies to the standard product. Our range of options usually allow us to accommodate any differences you may require. Please contact us and we will be happy to support you in developing this specification to meet your requirements.

Manufacturer: Fitzpatrick Woolmer,
Unit 7 Lakeside Park, Neptune Close,
Rochester, Kent, ME2 4LT.

Tel: 01634 711 771

Email: info@fwdp.co.uk

Material: Polystyrene foam

Origin: UK

Certification: 100% recycled plastic waste

Finish: Cedar effect

Visible fixings: Stainless steel security fixings to removable parts

Capacity: Will accommodate a 3mm thick printed graphic panel

Weight: 30kg

Installation: Posts extend 600mm below ground level

Guarantee: One year manufacturer's warranty

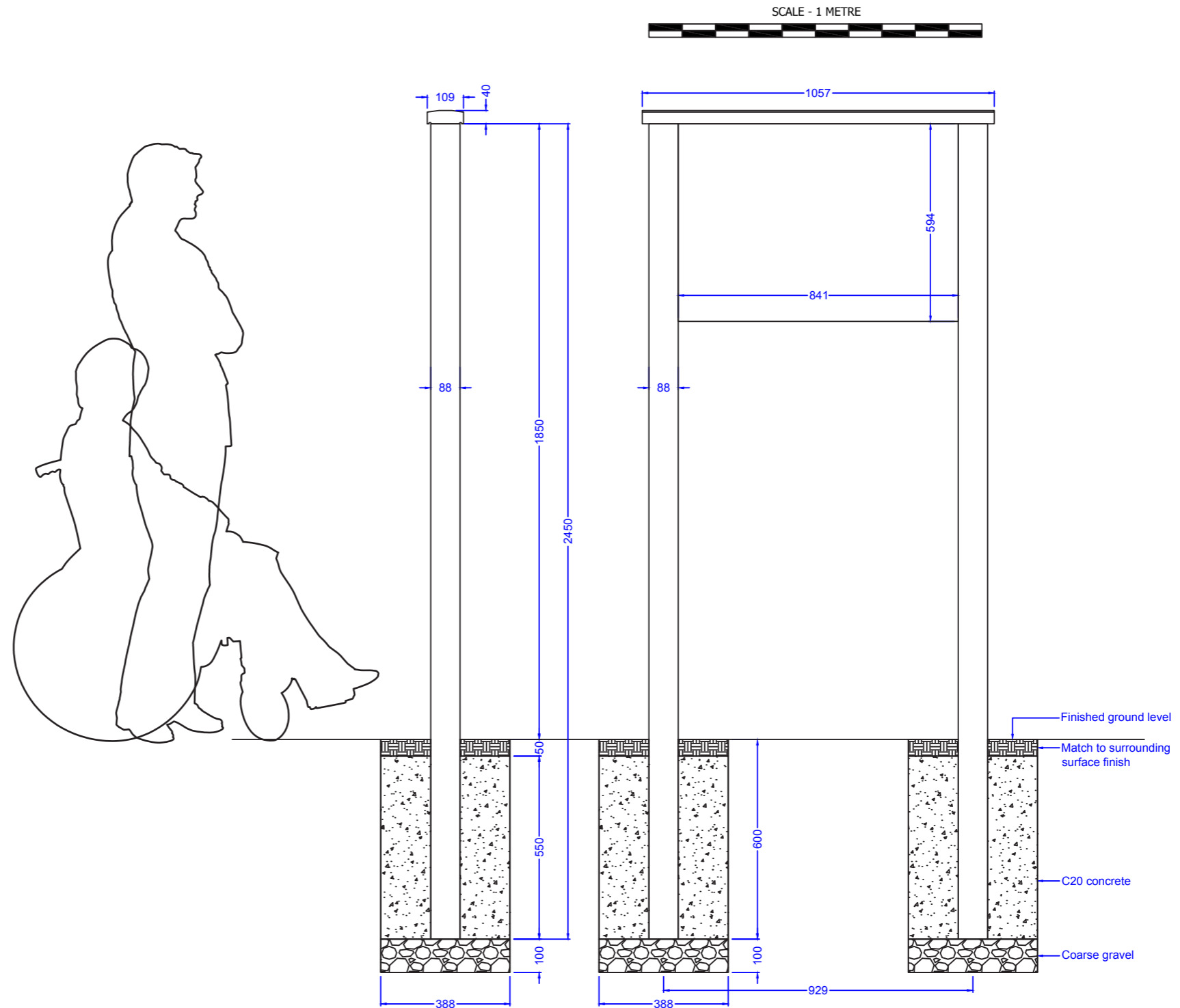
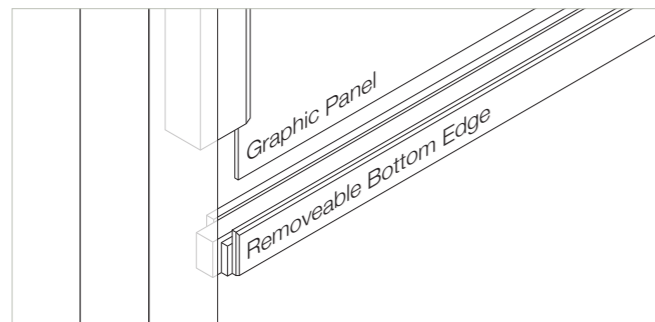

Note: All dimensions are indicative only. Footing details are subject to soil conditions and structural engineers recommendations.

Specification applies to the standard product. Our range of options usually allow us to accommodate any differences you may require. Please contact us and we will be happy to support you in developing this specification to meet your requirements.

Manufacturer: Fitzpatrick Woolmer,
Unit 7 Lakeside Park, Neptune Close,
Rochester, Kent, ME2 4LT.

Tel: 01634 711 771

Email: info@fwdp.co.uk

Material: Polystyrene foam

Origin: UK

Certification: 100% recycled plastic waste

Finish: Cedar effect

Visible fixings: Stainless steel security fixings to removable parts

Capacity: Will accommodate a 3mm thick printed graphic panel

Weight: 27kg

Installation: Posts extend 600mm below ground level

Guarantee: One year manufacturer's warranty

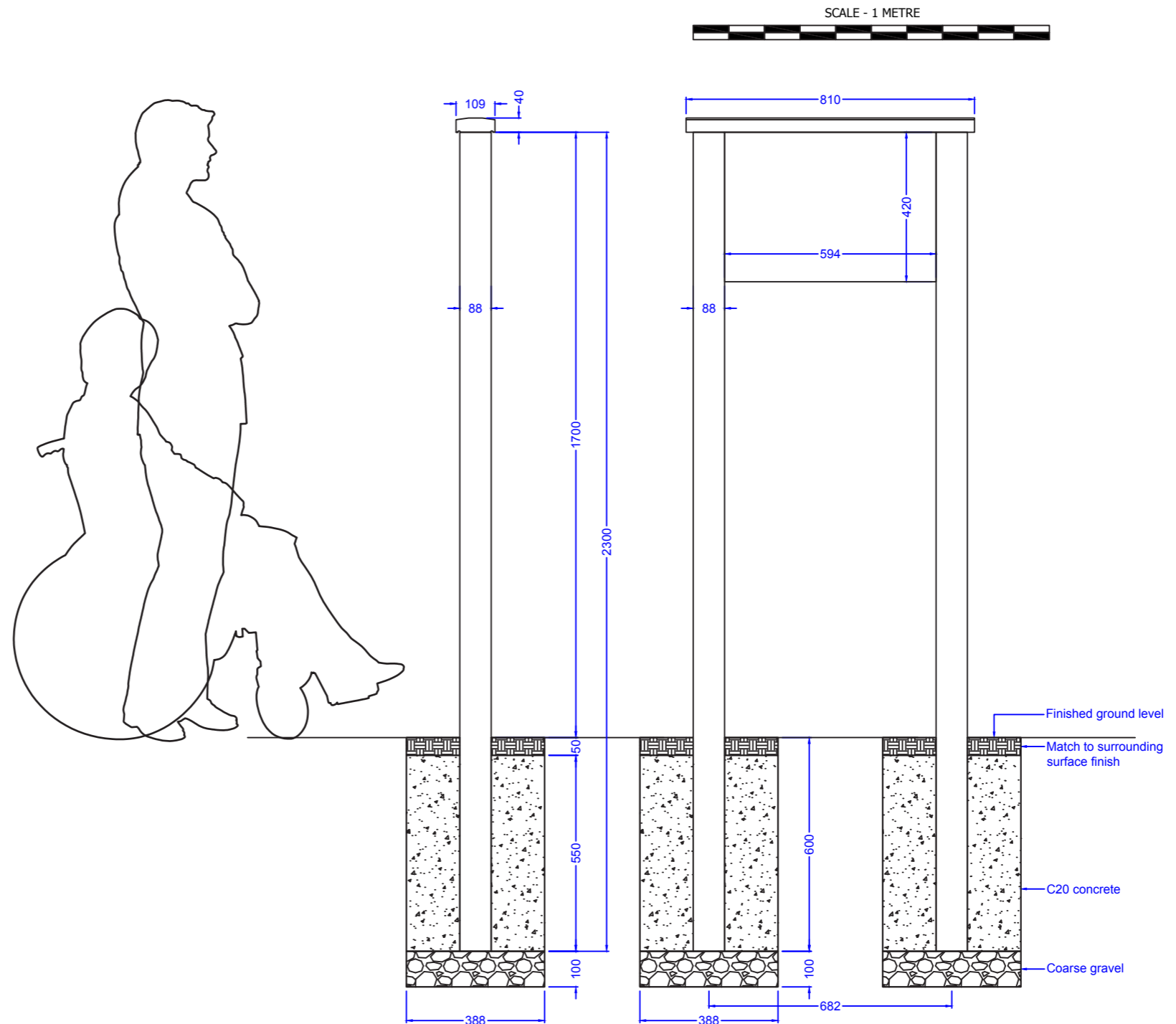
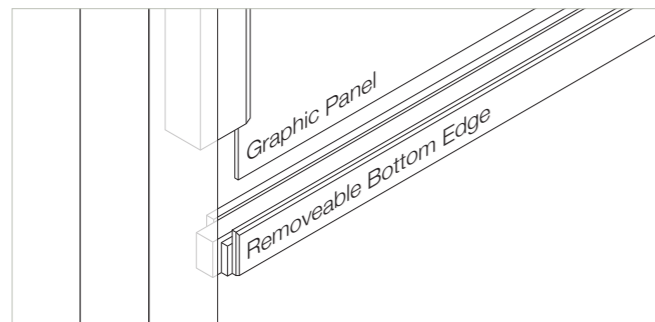

Note: All dimensions are indicative only. Footing details are subject to soil conditions and structural engineers recommendations.