



**Fitzpatrick
Woolmer**

Bowman™ Option C

Our rustic Oak Option C **Bowman™** information displays provide a highly visible, durable solution ideal for country parks, nature reserves, and historic attractions. Their natural appearance blends with outdoor landscapes while ensuring clear visibility for visitors.

These displays effectively welcome visitors, guide them with wayfinding information, and share unique facts about the site's natural history and heritage. They enhance the visitor experience by offering both practical and educational insights at key points along their journey.

Product features

- * Hardwood FSC Oak construction
- * Tamper resistant fixings
- * Removable graphic panel
- * Preservative finish
- * Standard sizes A2, A1 and A0
- * 1 year manufacturer's warranty

Fitzpatrick Woolmer Design & Publishing Limited

Unit 7 Lakeside Park, Neptune Close, Rochester, Kent, ME2 4LT
t: 01634 711 771 e: info@fwdp.co.uk w: fwdp.co.uk



By Appointment to His Majesty The King
Manufacturer of Signs and Wayfinding
Fitzpatrick Woolmer Design & Publishing Ltd, Kent

Specification applies to the standard product. Our range of options usually allow us to accommodate any differences you may require. Please contact us and we will be happy to support you in developing this specification to meet your requirements.

Option delete/ update as appropriate

Manufacturer: Fitzpatrick Woolmer,
 Unit 7 Lakeside Park, Neptune Close,
 Rochester, Kent, ME2 4LT.
 Tel: 01634 711 771
 Email: info@fwdp.co.uk

Timber: FSC Prime Grade to BS EN 975-1

Species: Oak and Eucalyptus (external grade plywood)

Origin: France and China

Moisture content on delivery: 10% - 20%

Certification: FSC chain of custody

Finish: Sadolin Classic wood preservative, solvent based, matt

Colour: Light Oak

Visible fixings: Stainless steel security fixings to removable parts

Capacity: Will accommodate a 3mm thick printed graphic panel

Weight: 69kg

Installation: Posts extend 600mm below ground level

Guarantee: One year manufacturer's warranty

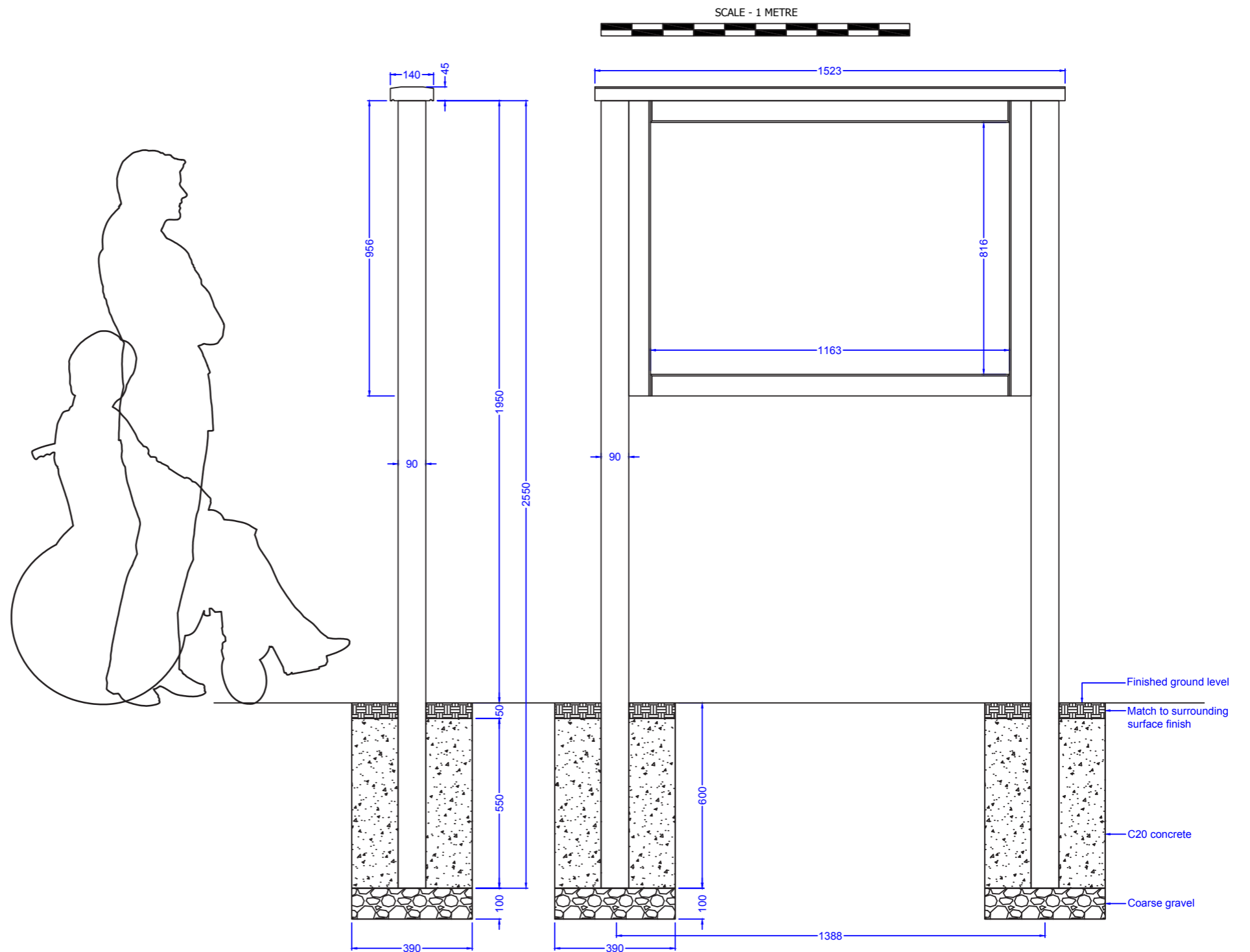
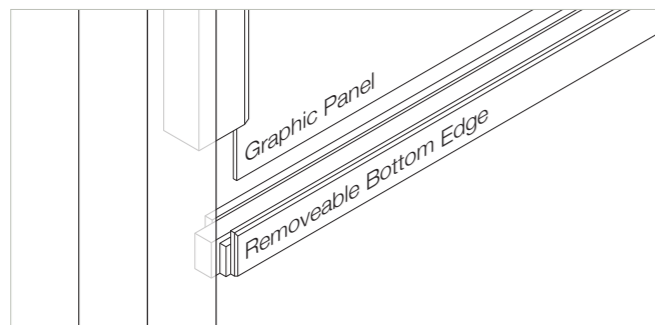

Note: All dimensions are indicative only. Footing details are subject to soil conditions and structural engineers recommendations.

Specification applies to the standard product. Our range of options usually allow us to accommodate any differences you may require. Please contact us and we will be happy to support you in developing this specification to meet your requirements.

Option delete/ update as appropriate

Manufacturer: Fitzpatrick Woolmer,
 Unit 7 Lakeside Park, Neptune Close,
 Rochester, Kent, ME2 4LT.
 Tel: 01634 711 771
 Email: info@fwdp.co.uk

Timber: FSC Prime Grade to BS EN 975-1

Species: Oak and Eucalyptus (external grade plywood)

Origin: France and China

Moisture content on delivery: 10% - 20%

Certification: FSC chain of custody

Finish: Sadolin Classic wood preservative, solvent based, matt

Colour: Light Oak

Visible fixings: Stainless steel security fixings to removable parts

Capacity: Will accommodate a 3mm thick printed graphic panel

Weight: 42kg

Installation: Posts extend 600mm below ground level

Guarantee: One year manufacturer's warranty

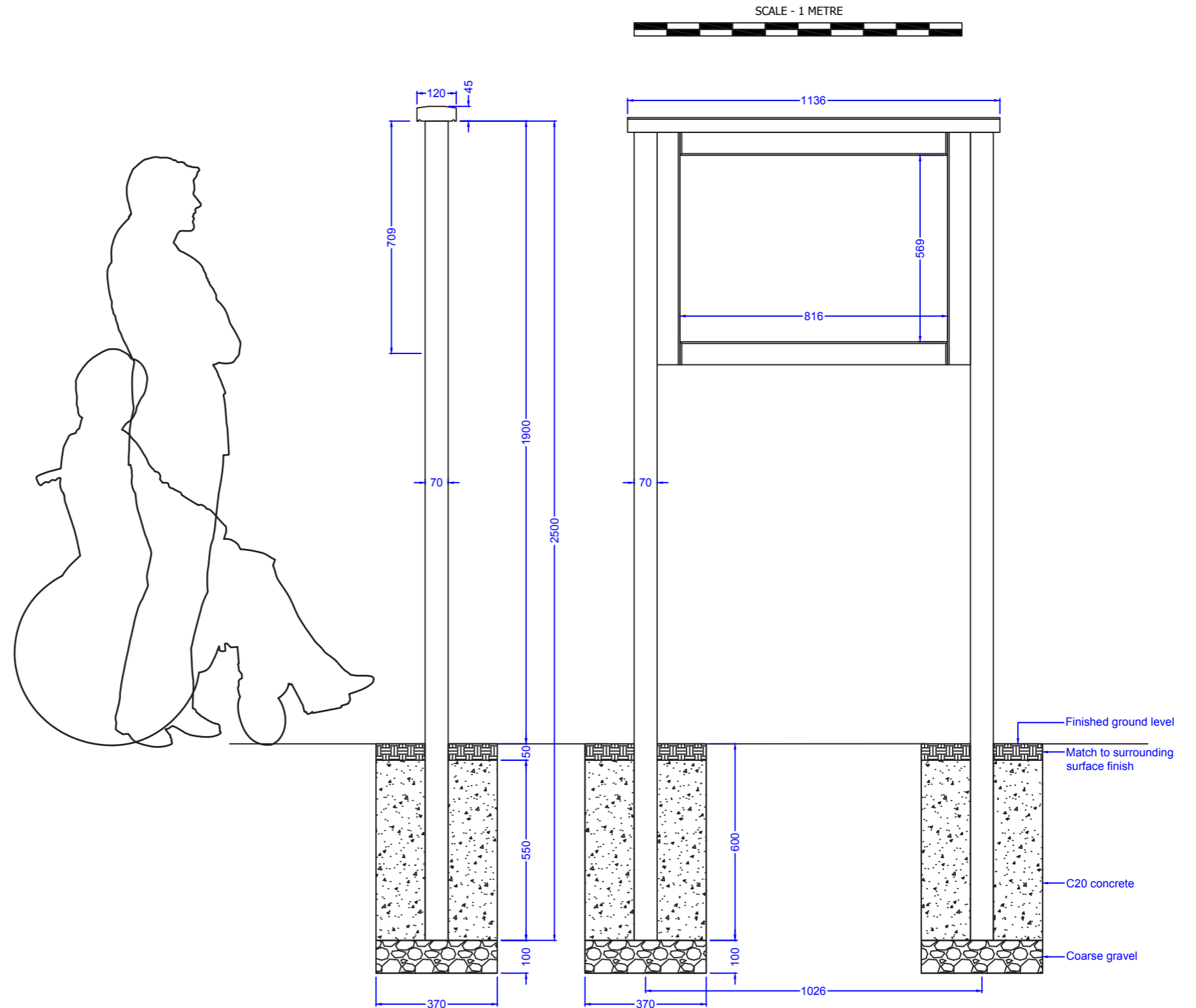
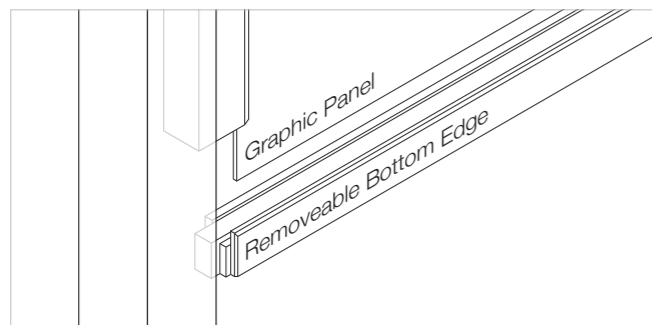

Note: All dimensions are indicative only. Footing details are subject to soil conditions and structural engineers recommendations.

Specification applies to the standard product. Our range of options usually allow us to accommodate any differences you may require. Please contact us and we will be happy to support you in developing this specification to meet your requirements.

Option delete/ update as appropriate

Manufacturer: Fitzpatrick Woolmer,
 Unit 7 Lakeside Park, Neptune Close,
 Rochester, Kent, ME2 4LT.
 Tel: 01634 711 771
 Email: info@fwdp.co.uk

Timber: FSC Prime Grade to BS EN 975-1

Species: Oak and Eucalyptus (external grade plywood)

Origin: France and China

Moisture content on delivery: 10% - 20%

Certification: FSC chain of custody

Finish: Sadolin Classic wood preservative, solvent based, matt

Colour: Light Oak

Visible fixings: Stainless steel security fixings to removable parts

Capacity: Will accommodate a 3mm thick printed graphic panel

Weight: 35kg

Installation: Posts extend 600mm below ground level

Guarantee: One year manufacturer's warranty

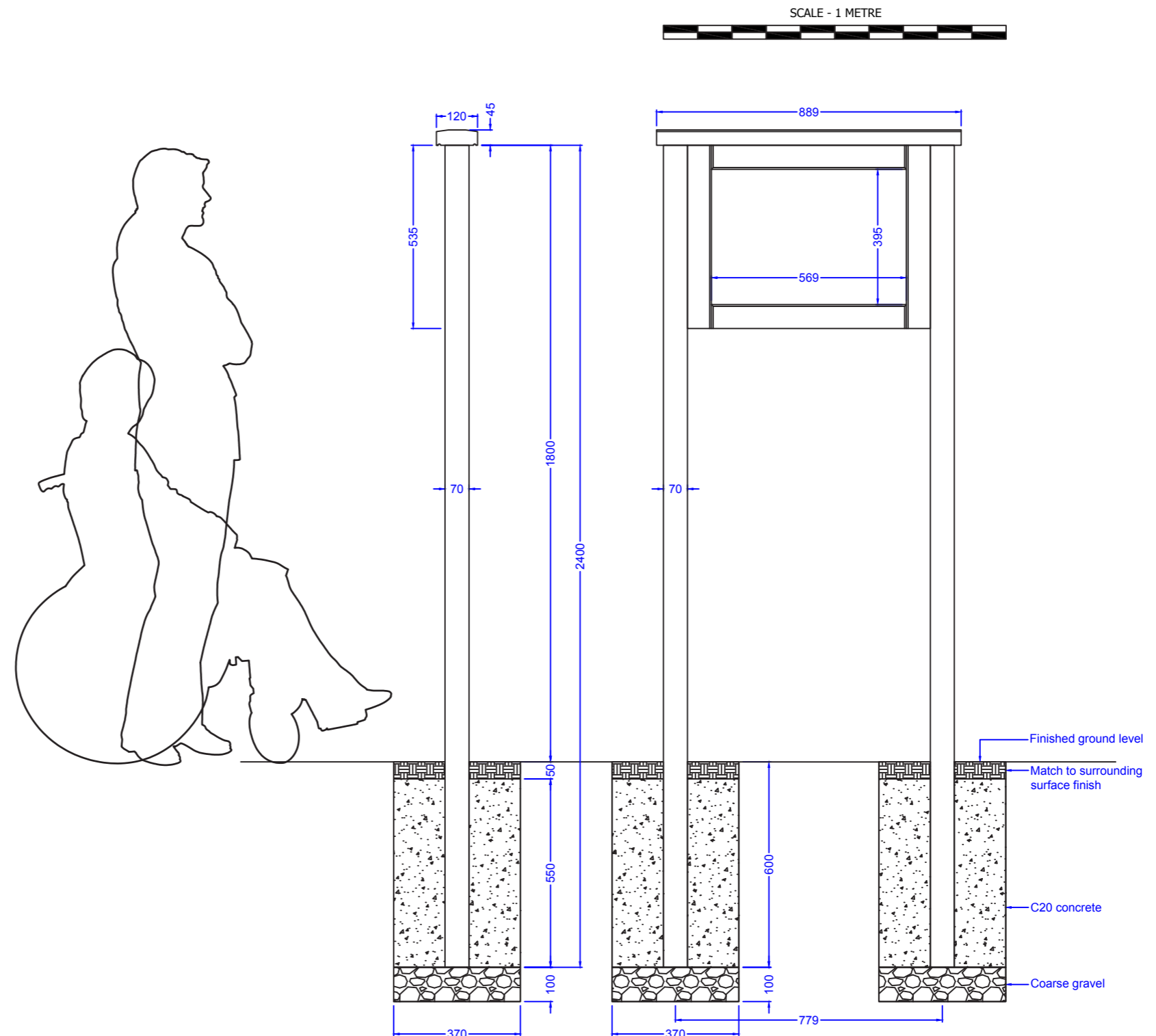
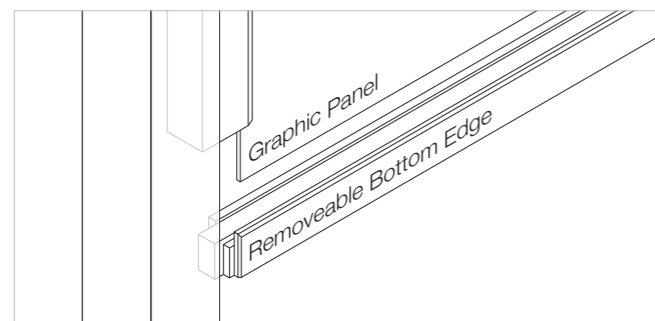

Note: All dimensions are indicative only. Footing details are subject to soil conditions and structural engineers recommendations.