



# Fitzpatrick Woolmer

## Recycled Plastic **Bowman™ Option C**

Our recycled plastic Option C **Bowman™** information displays provide a highly visible, durable solution ideal for country parks, nature reserves, and historic attractions. Made from 100% recycled UK plastic waste, they offer an eco-friendly information display solution that requires minimal maintenance and will never rot or degrade.

These displays effectively welcome visitors, guide them with wayfinding information, and share unique facts about the site's natural history and heritage. They enhance the visitor experience by offering both practical and educational insights at key points along their journey.

### Product features

- \* Wood effect recycled plastic construction
- \* 100% recyclable
- \* No maintenance required
- \* Tamper resistant fixings
- \* Removable graphic panel
- \* Cedar effect finish
- \* Standard sizes A3, A2 and A1
- \* 1 year manufacturer's warranty

### Fitzpatrick Woolmer Design & Publishing Limited

Unit 7 Lakeside Park, Neptune Close, Rochester, Kent, ME2 4LT  
t: 01634 711 771 e: info@fwdp.co.uk w: fwdp.co.uk



By Appointment to His Majesty The King  
Manufacturer of Signs and Wayfinding  
Fitzpatrick Woolmer Design & Publishing Ltd, Kent

Specification applies to the standard product. Our range of options usually allow us to accommodate any differences you may require. Please contact us and we will be happy to support you in developing this specification to meet your requirements.

**Manufacturer:** Fitzpatrick Woolmer,  
Unit 7 Lakeside Park, Neptune Close,  
Rochester, Kent, ME2 4LT.

**Tel:** 01634 711 771

**Email:** info@fwdp.co.uk

**Material:** Polystyrene foam

**Origin:** UK

**Certification:** 100% recycled plastic waste

**Finish:** Cedar effect

**Visible fixings:** Stainless steel security fixings to removable parts

**Capacity:** Will accommodate a 3mm thick printed graphic panel

**Weight:** 46kg

**Installation:** Posts extend 600mm below ground level

**Guarantee:** One year manufacturer's warranty

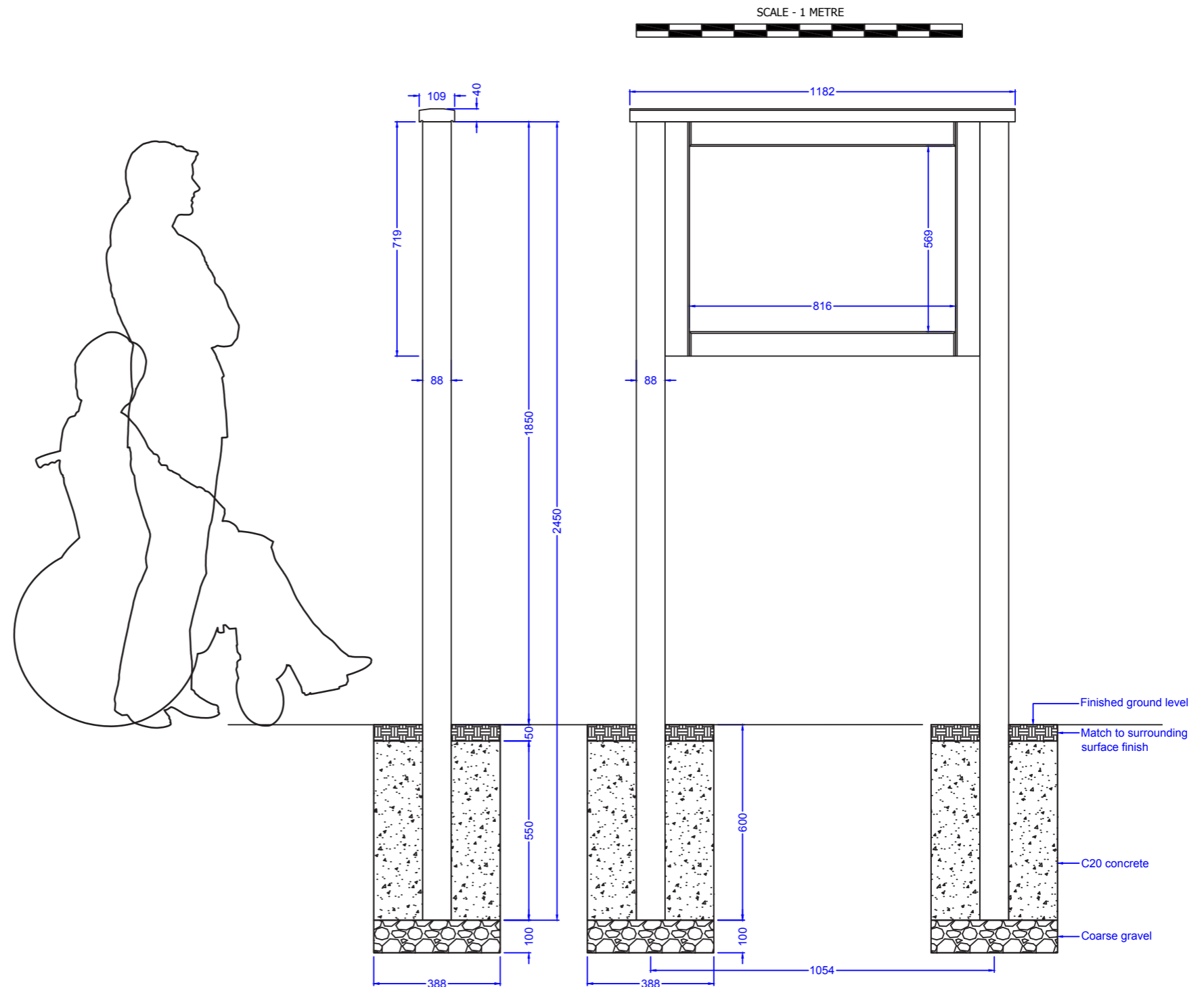
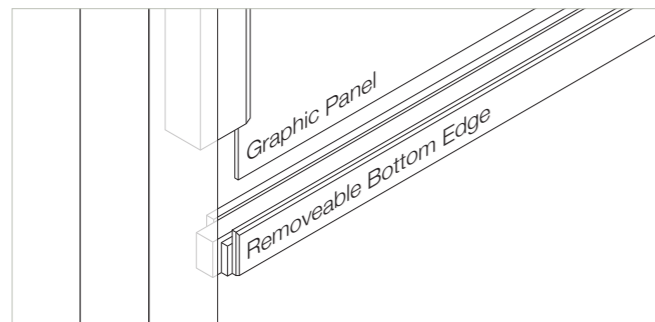

Note: All dimensions are indicative only. Footing details are subject to soil conditions and structural engineers recommendations.



