



**Fitzpatrick
Woolmer**

Wallmounting Notice Board - Recycled Plastic

Our **wall-mounting recycled plastic notice boards** provide a sustainable, low-maintenance solution for public information display. Made from durable, weather-resistant materials, they are ideal for parks, schools, and community settings. The design blends traditional and modern elements, making them suitable for a wide range of environments.

Available in single or double door options, each board features secure, lockable doors to protect contents. Built to last with minimal upkeep, they offer an eco-friendly, practical alternative to timber or metal.

Product features

- * Wood effect recycled plastic and stainless steel construction
- * 100% recyclable
- * No maintenance required
- * Can be supplied with or without a header board
- * Robust stainless steel locks
- * Gas struts to support doors when open
- * Tough 4mm clear polycarbonate window
- * Vent holes to minimise condensation
- * Standard sizes A2, A1 and A0
- * 1 year manufacturer's warranty

Fitzpatrick Woolmer Design & Publishing Limited

Unit 7 Lakeside Park, Neptune Close, Rochester, Kent, ME2 4LT
t: 01634 711 771 e: info@fwdp.co.uk w: fwdp.co.uk



By Appointment to His Majesty The King
Manufacturer of Signs and Wayfinding
Fitzpatrick Woolmer Design & Publishing Ltd, Kent

Specification applies to the standard product. Our range of options usually allow us to accommodate any differences you may require. Please contact us and we will be happy to support you in developing this specification to meet your requirements.

Manufacturer: Fitzpatrick Woolmer,
Unit 7 Lakeside Park, Neptune Close,
Rochester, Kent, ME2 4LT.

Tel: 01634 711 771

Email: info@fwdp.co.uk

Material: Polystyrene foam

Origin: UK

Certification: 100% recycled plastic waste

Finish: Cedar effect

Weight: 44kg

Guarantee: One year manufacturer's warranty

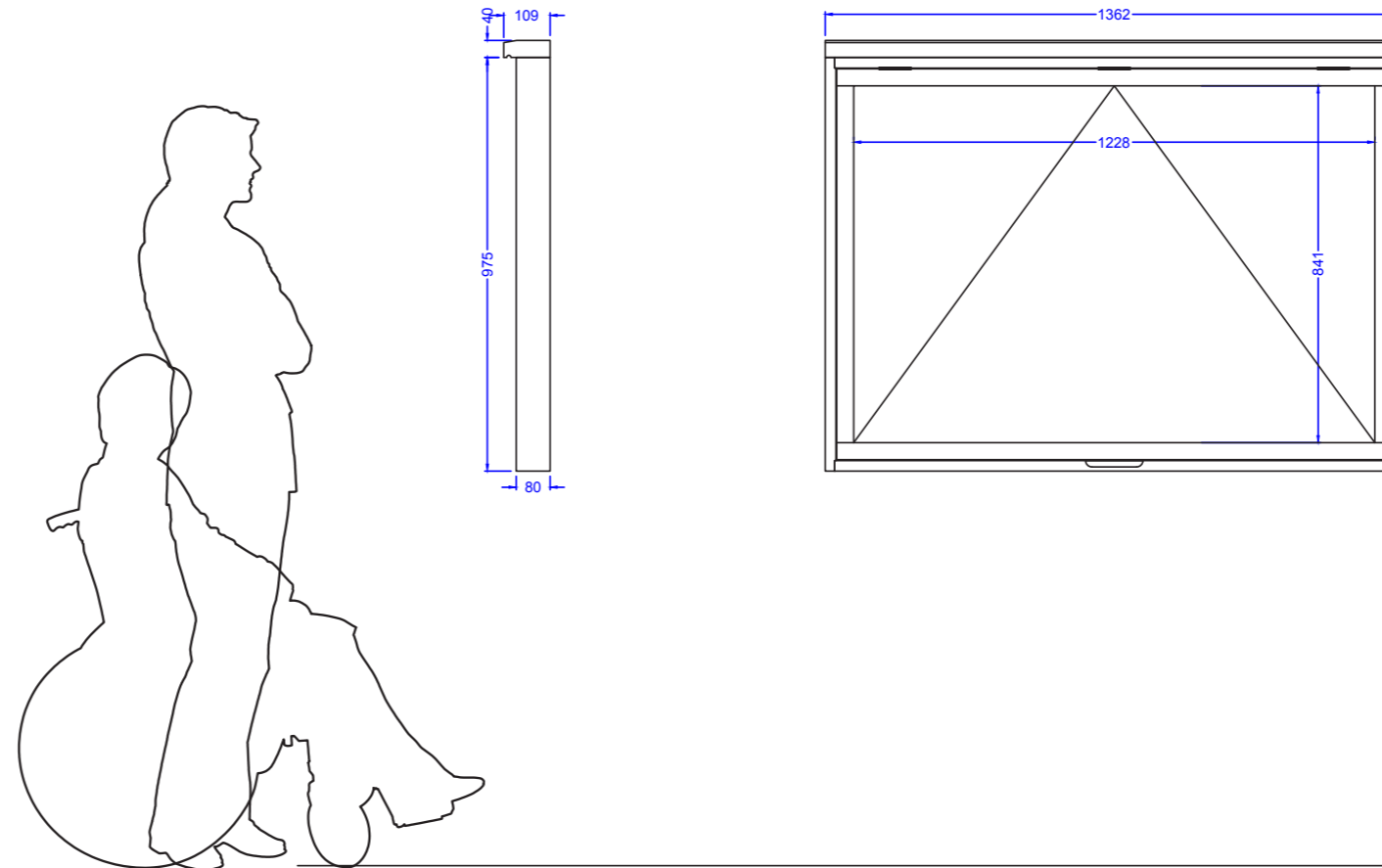

Note: All dimensions are indicative only. Footing details are subject to soil conditions and structural engineers recommendations.

Specification applies to the standard product.
Our range of options usually allow us to accommodate any differences you may require.
Please contact us and we will be happy to support you in developing this specification to meet your requirements.

Manufacturer: Fitzpatrick Woolmer,
Unit 7 Lakeside Park, Neptune Close,
Rochester, Kent, ME2 4LT.
Tel: 01634 711 771
Email: info@fwdp.co.uk

Material: Polystyrene foam

Origin: UK

Certification: 100% recycled plastic waste

Finish: Cedar effect

Weight: 48kg

Guarantee: One year manufacturer's warranty

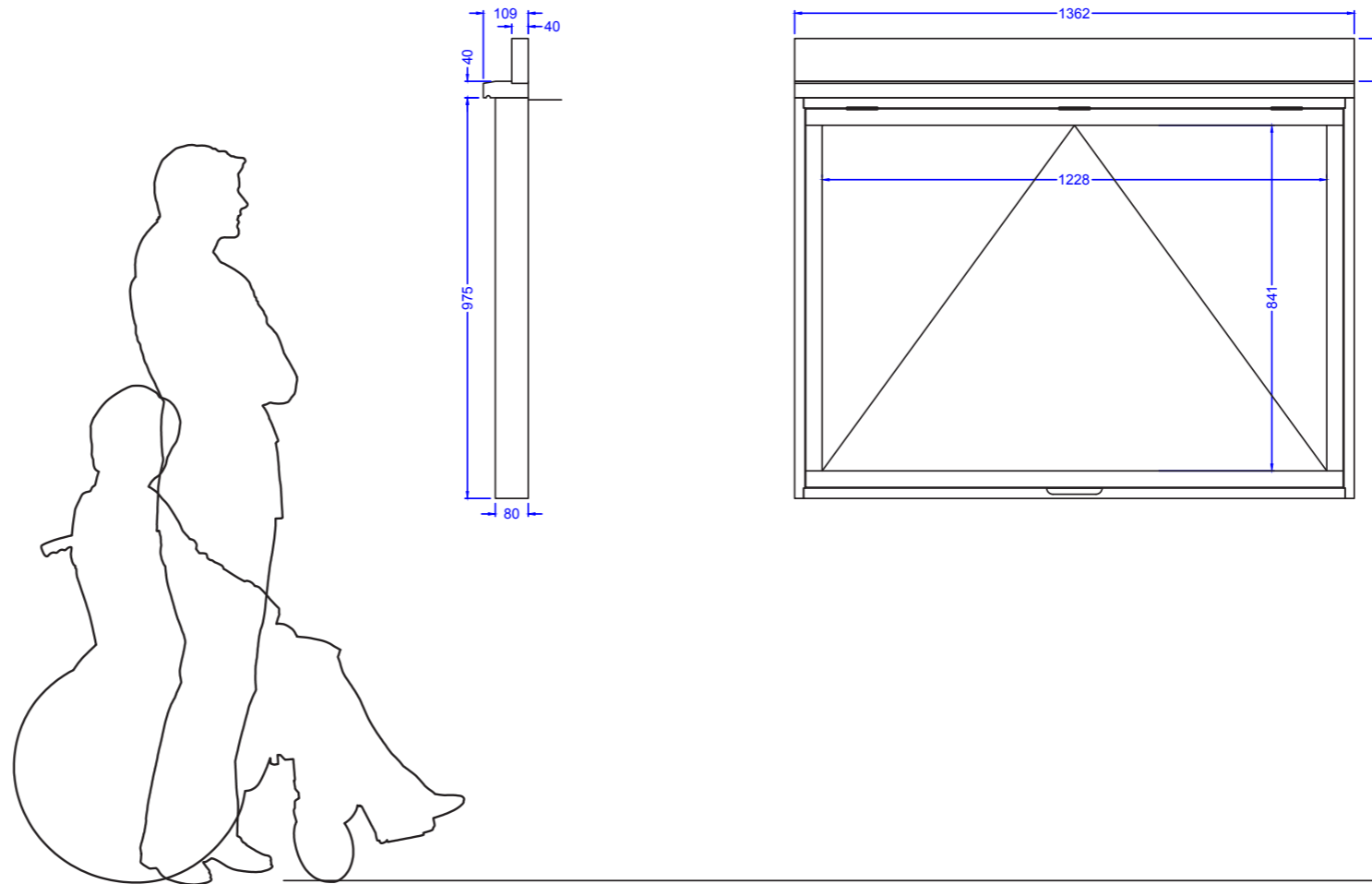

Note: All dimensions are indicative only. Footing details are subject to soil conditions and structural engineers recommendations.

Specification applies to the standard product. Our range of options usually allow us to accommodate any differences you may require. Please contact us and we will be happy to support you in developing this specification to meet your requirements.

Manufacturer: Fitzpatrick Woolmer,
Unit 7 Lakeside Park, Neptune Close,
Rochester, Kent, ME2 4LT.

Tel: 01634 711 771

Email: info@fwdp.co.uk

Material: Polystyrene foam

Origin: UK

Certification: 100% recycled plastic waste

Finish: Cedar effect

Weight: 51kg

Guarantee: One year manufacturer's warranty

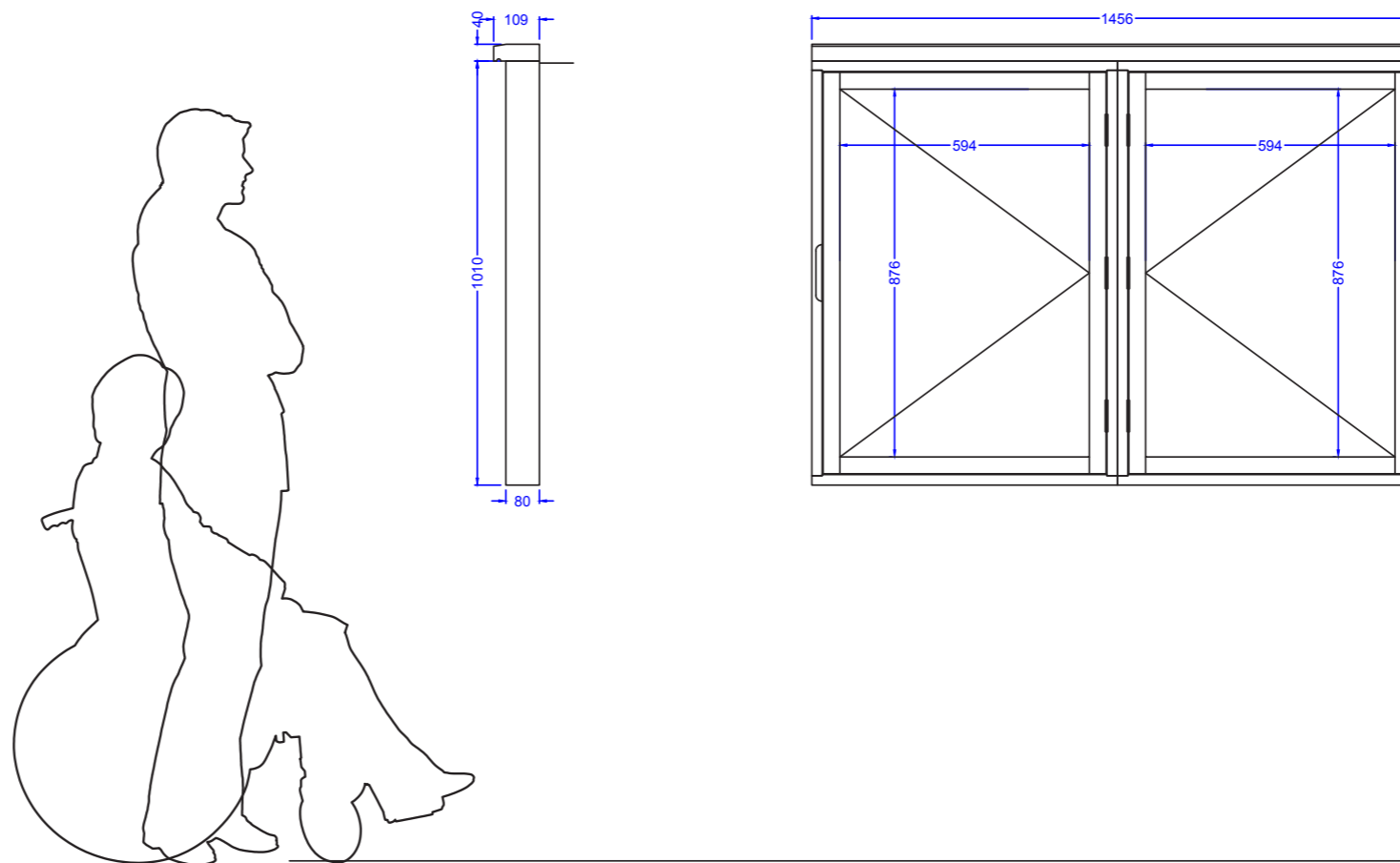

Note: All dimensions are indicative only. Footing details are subject to soil conditions and structural engineers recommendations.

Specification applies to the standard product. Our range of options usually allow us to accommodate any differences you may require. Please contact us and we will be happy to support you in developing this specification to meet your requirements.

Manufacturer: Fitzpatrick Woolmer,
Unit 7 Lakeside Park, Neptune Close,
Rochester, Kent, ME2 4LT.

Tel: 01634 711 771

Email: info@fwdp.co.uk

Material: Polystyrene foam

Origin: UK

Certification: 100% recycled plastic waste

Finish: Cedar effect

Weight: 55kg

Guarantee: One year manufacturer's warranty

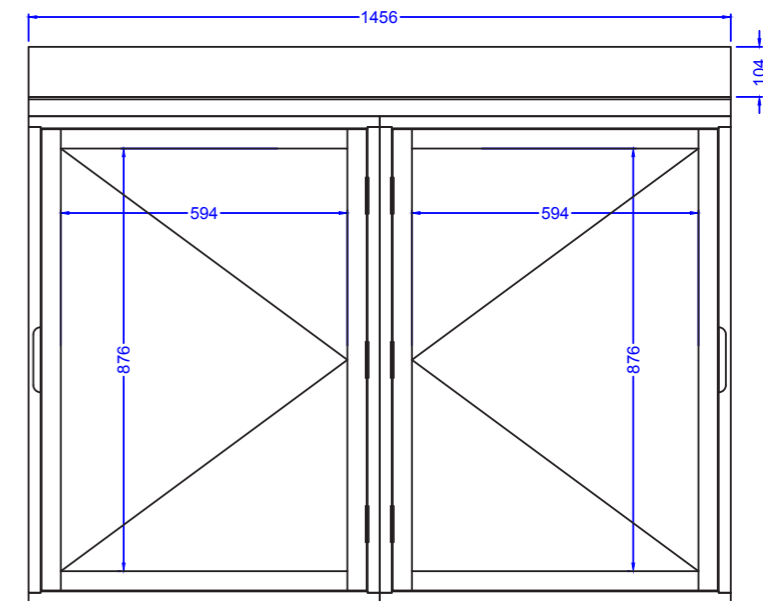
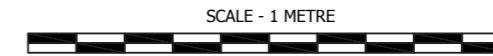
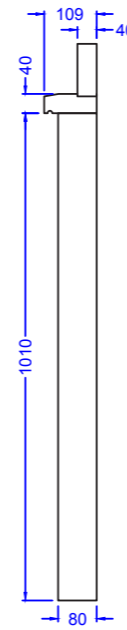
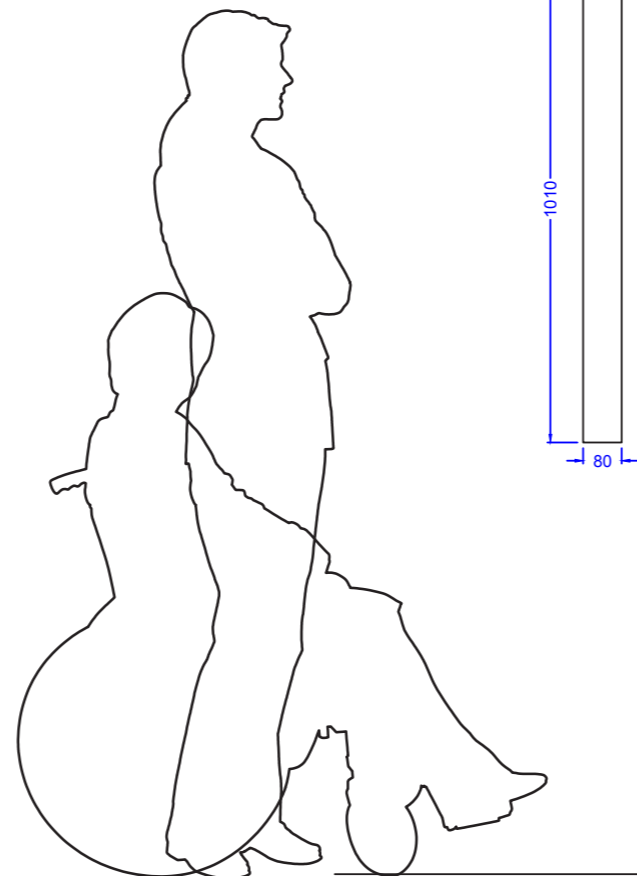

Note: All dimensions are indicative only. Footing details are subject to soil conditions and structural engineers recommendations.

Specification applies to the standard product. Our range of options usually allow us to accommodate any differences you may require. Please contact us and we will be happy to support you in developing this specification to meet your requirements.

Manufacturer: Fitzpatrick Woolmer,
Unit 7 Lakeside Park, Neptune Close,
Rochester, Kent, ME2 4LT.
Tel: 01634 711 771
Email: info@fwdp.co.uk

Material: Polystyrene foam

Origin: UK

Certification: 100% recycled plastic waste

Finish: Cedar effect

Weight: 27kg

Guarantee: One year manufacturer's warranty

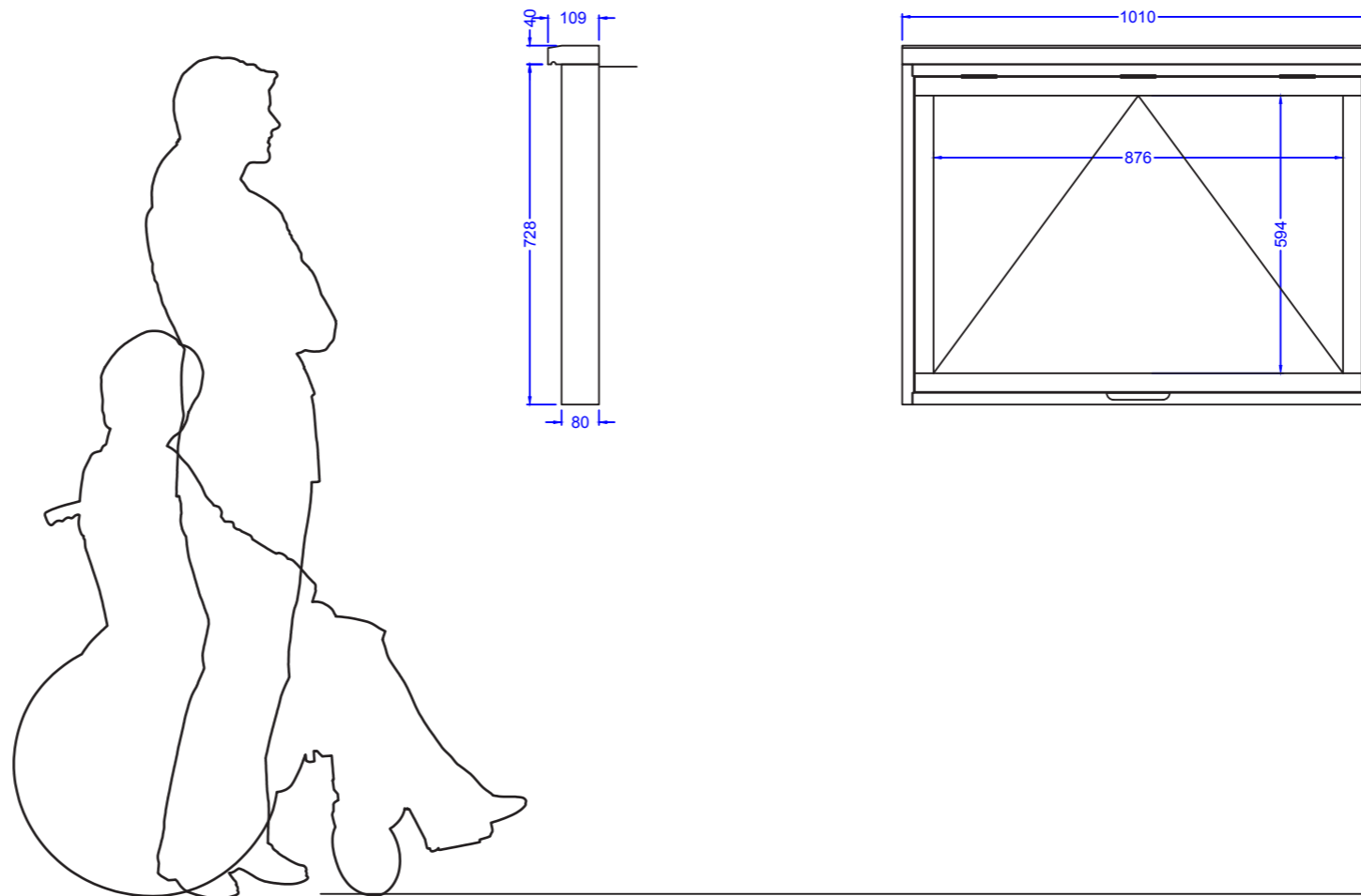
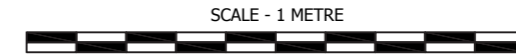

Note: All dimensions are indicative only. Footing details are subject to soil conditions and structural engineers recommendations.

Specification applies to the standard product. Our range of options usually allow us to accommodate any differences you may require. Please contact us and we will be happy to support you in developing this specification to meet your requirements.

Manufacturer: Fitzpatrick Woolmer,
Unit 7 Lakeside Park, Neptune Close,
Rochester, Kent, ME2 4LT.

Tel: 01634 711 771

Email: info@fwdp.co.uk

Material: Polystyrene foam

Origin: UK

Certification: 100% recycled plastic waste

Finish: Cedar effect

Weight: 30kg

Guarantee: One year manufacturer's warranty

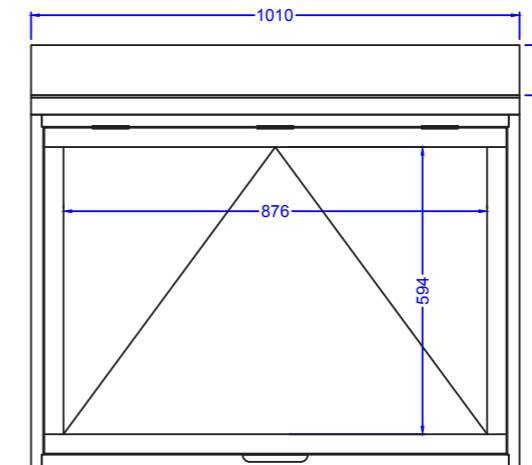
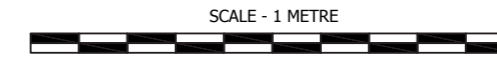
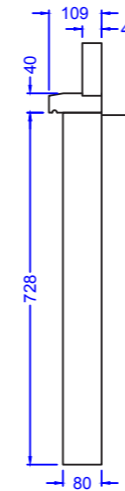
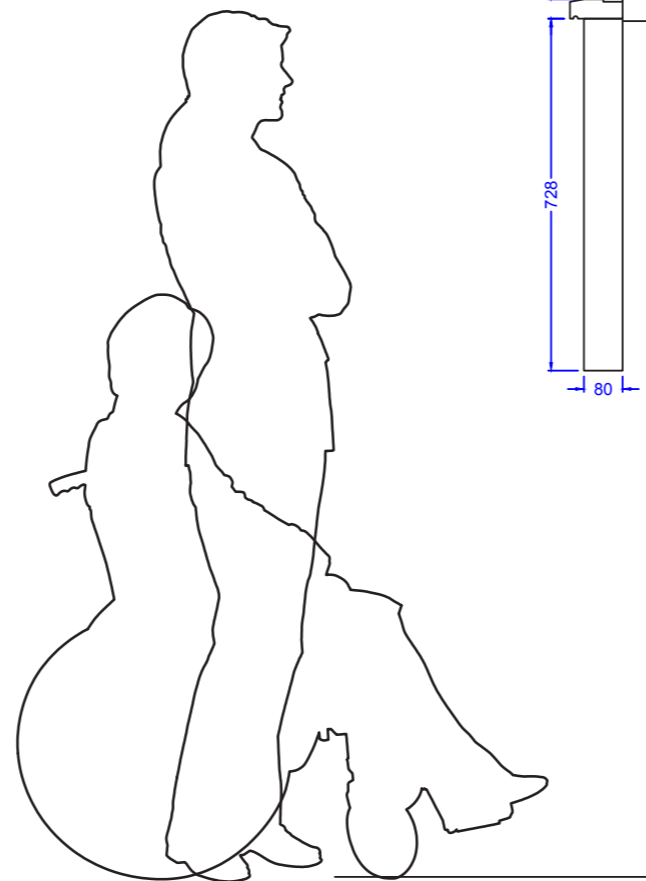

Note: All dimensions are indicative only. Footing details are subject to soil conditions and structural engineers recommendations.

Specification applies to the standard product. Our range of options usually allow us to accommodate any differences you may require. Please contact us and we will be happy to support you in developing this specification to meet your requirements.

Manufacturer: Fitzpatrick Woolmer,
Unit 7 Lakeside Park, Neptune Close,
Rochester, Kent, ME2 4LT.
Tel: 01634 711 771
Email: info@fwdp.co.uk

Material: Polystyrene foam

Origin: UK

Certification: 100% recycled plastic waste

Finish: Cedar effect

Weight: 33kg

Guarantee: One year manufacturer's warranty

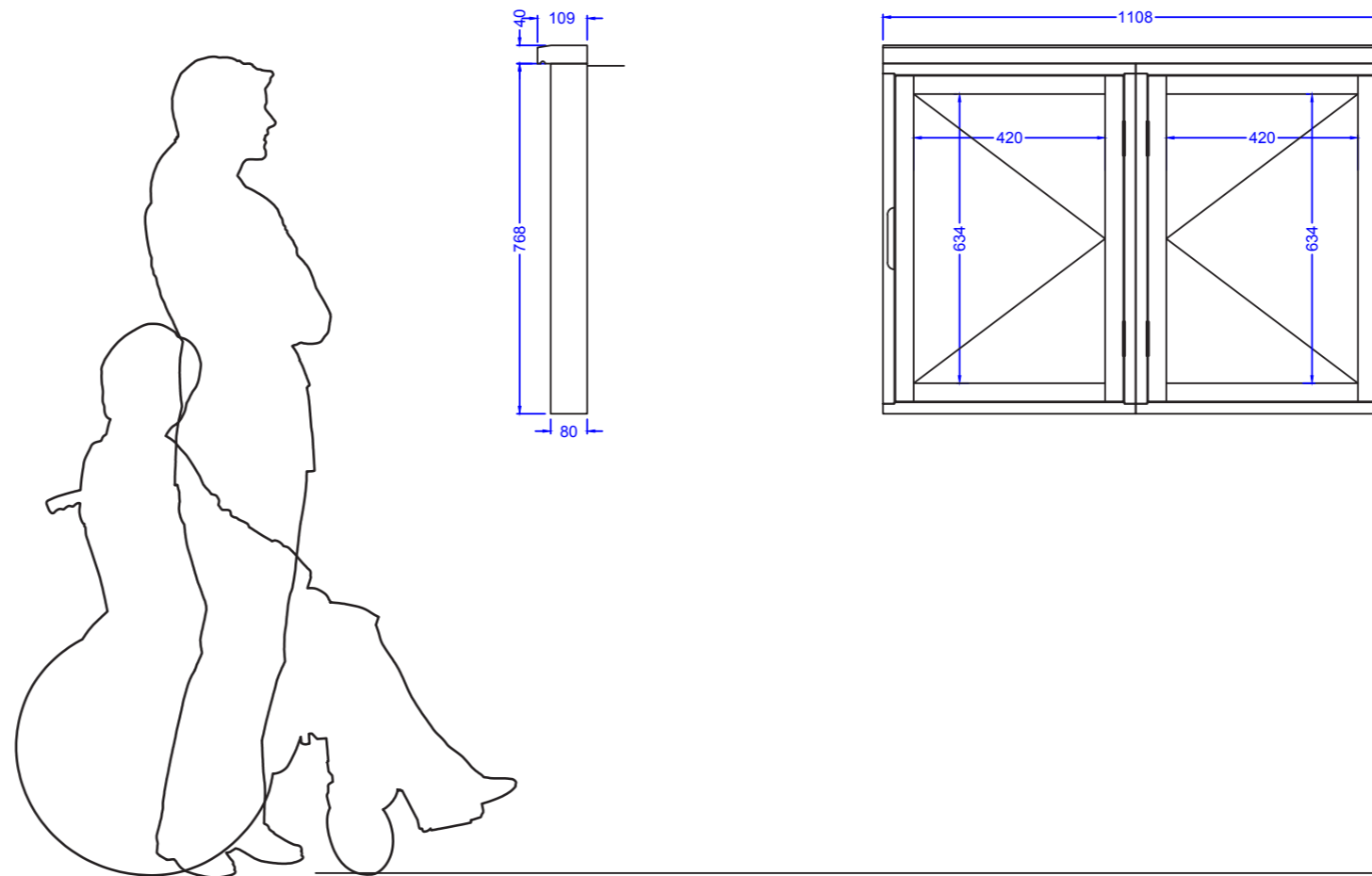

Note: All dimensions are indicative only. Footing details are subject to soil conditions and structural engineers recommendations.

Specification applies to the standard product. Our range of options usually allow us to accommodate any differences you may require. Please contact us and we will be happy to support you in developing this specification to meet your requirements.

Manufacturer: Fitzpatrick Woolmer,
Unit 7 Lakeside Park, Neptune Close,
Rochester, Kent, ME2 4LT.

Tel: 01634 711 771

Email: info@fwdp.co.uk

Material: Polystyrene foam

Origin: UK

Certification: 100% recycled plastic waste

Finish: Cedar effect

Weight: 36kg

Guarantee: One year manufacturer's warranty

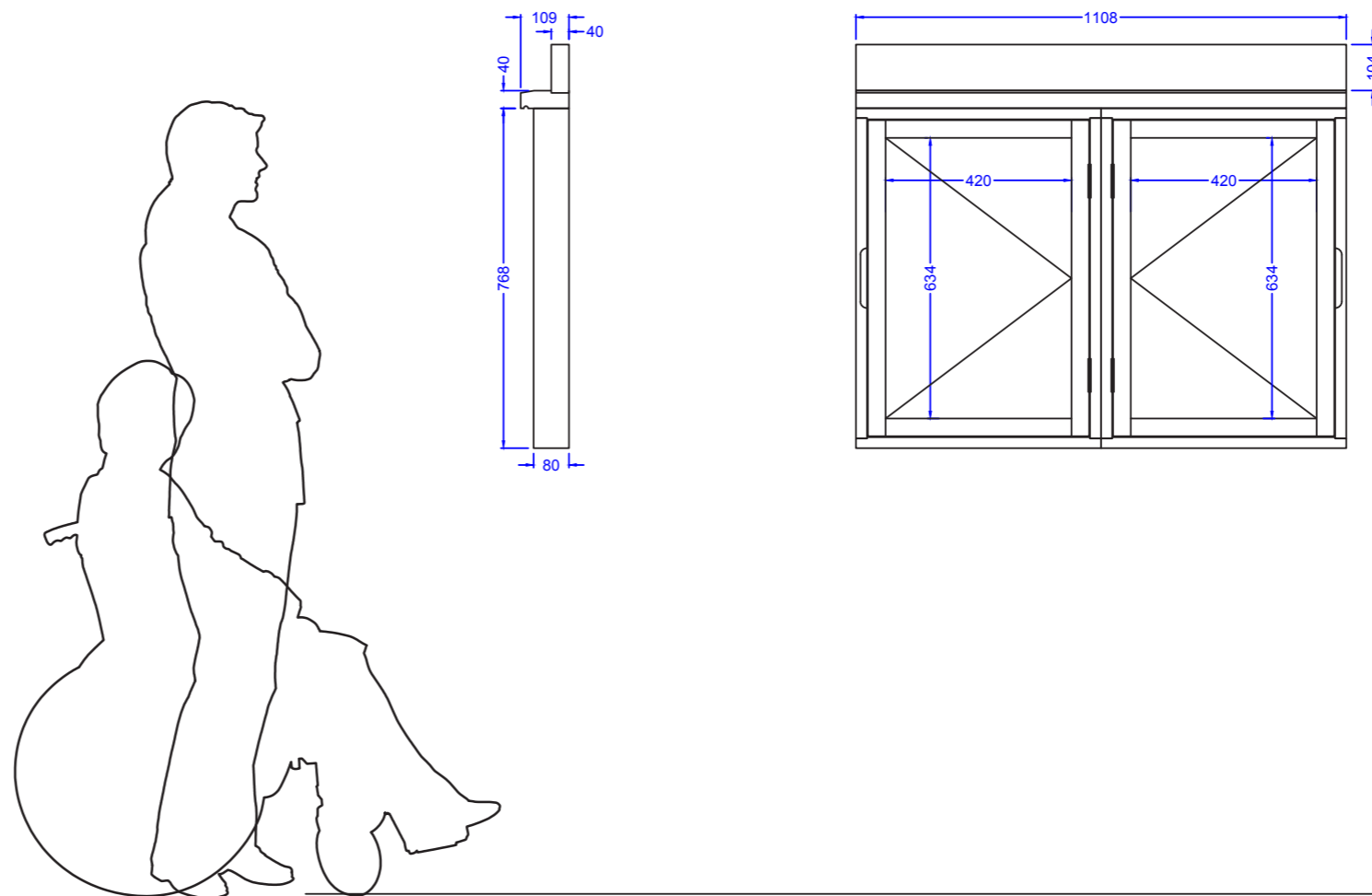

Note: All dimensions are indicative only. Footing details are subject to soil conditions and structural engineers recommendations.

Specification applies to the standard product.
Our range of options usually allow us to accommodate any differences you may require.
Please contact us and we will be happy to support you in developing this specification to meet your requirements.

Manufacturer: Fitzpatrick Woolmer,
Unit 7 Lakeside Park, Neptune Close,
Rochester, Kent, ME2 4LT.
Tel: 01634 711 771
Email: info@fwdp.co.uk

Material: Polystyrene foam

Origin: UK

Certification: 100% recycled plastic waste

Finish: Cedar effect

Weight: 18kg

Guarantee: One year manufacturer's warranty

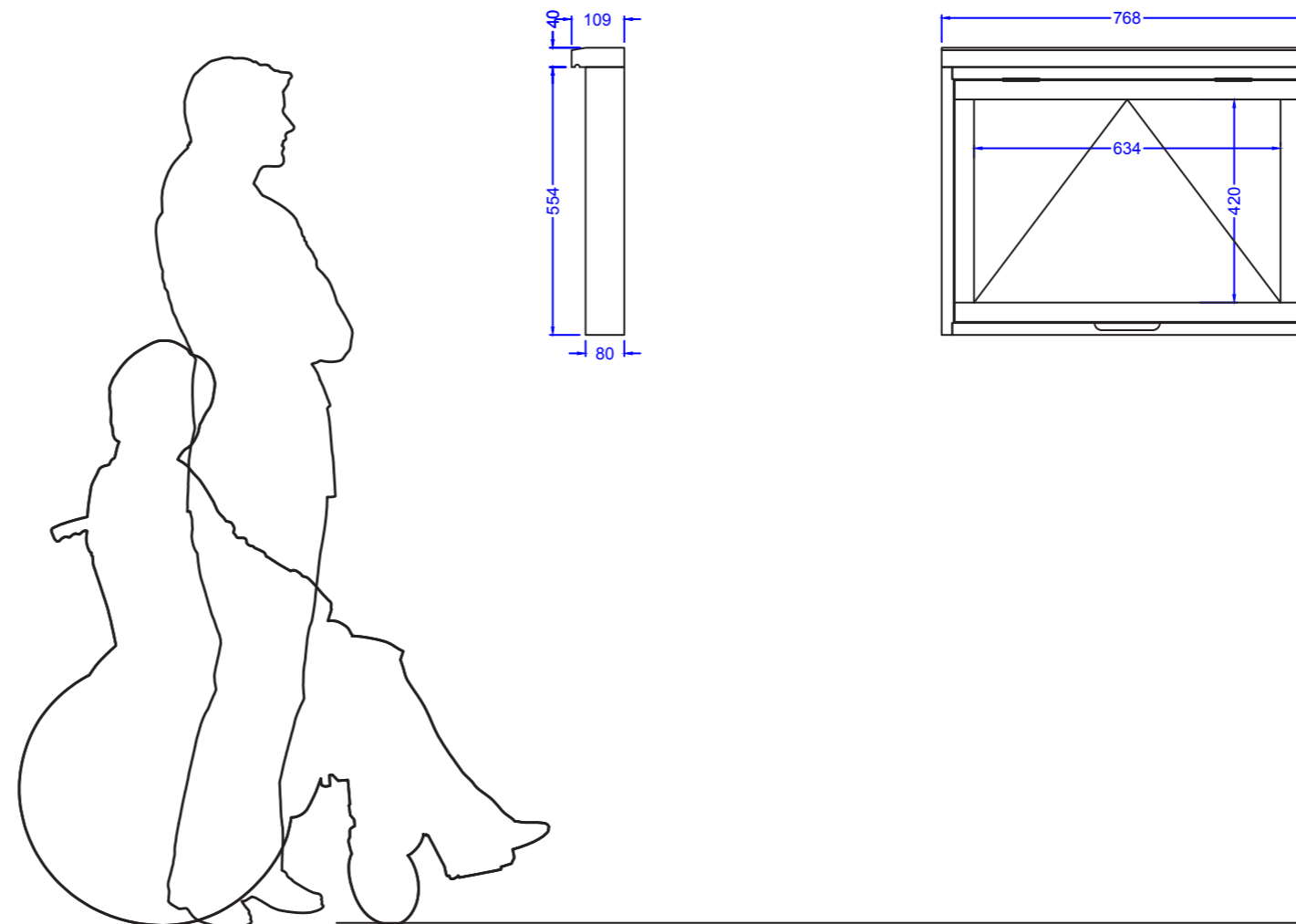
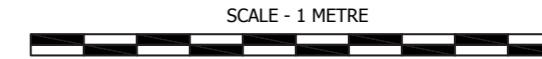

Note: All dimensions are indicative only. Footing details are subject to soil conditions and structural engineers recommendations.

Specification applies to the standard product. Our range of options usually allow us to accommodate any differences you may require. Please contact us and we will be happy to support you in developing this specification to meet your requirements.

Manufacturer: Fitzpatrick Woolmer,
Unit 7 Lakeside Park, Neptune Close,
Rochester, Kent, ME2 4LT.

Tel: 01634 711 771

Email: info@fwdp.co.uk

Material: Polystyrene foam

Origin: UK

Certification: 100% recycled plastic waste

Finish: Cedar effect

Weight: 20kg

Guarantee: One year manufacturer's warranty

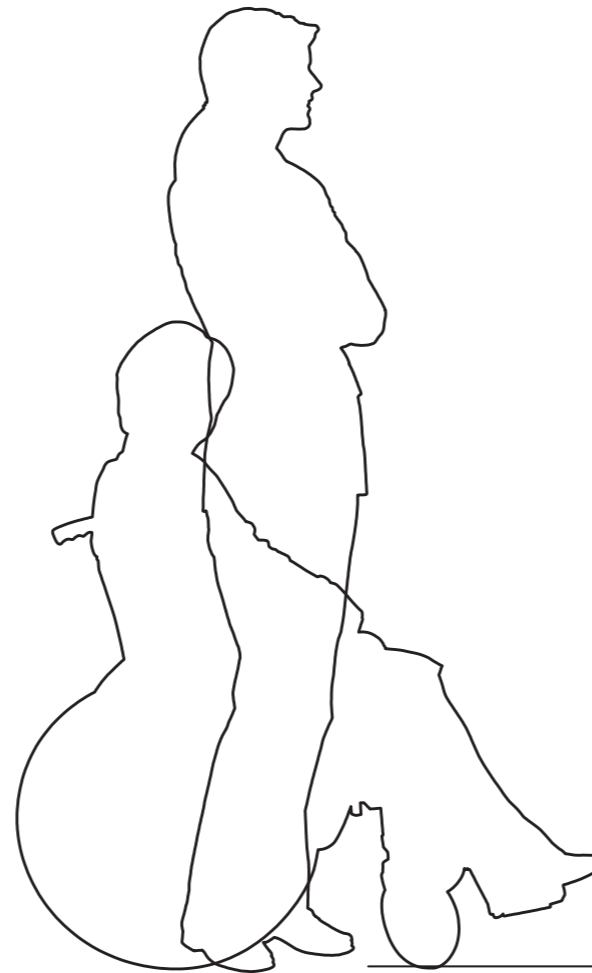
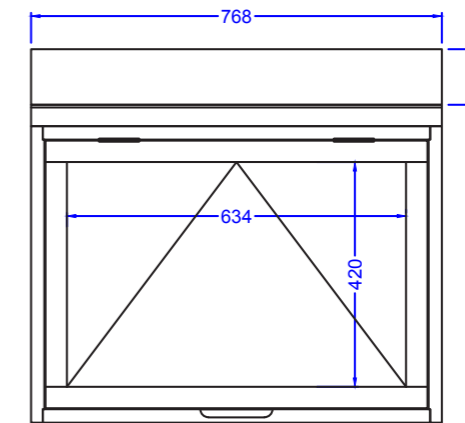
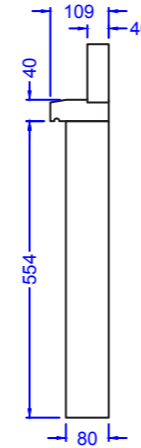
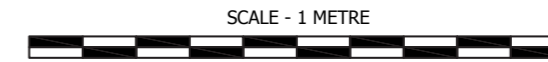

Note: All dimensions are indicative only. Footing details are subject to soil conditions and structural engineers recommendations.