



Fitzpatrick Woolmer

Recycled Plastic

Wallmounting Frame

Our **recycled plastic wallmounting frames** provide a durable, low-maintenance display solution with strong sustainability credentials. Manufactured in the UK from 100% recycled plastic waste and fully recyclable at end of life, they offer an eco-friendly alternative to traditional materials.

Designed for secure fixing to walls, they're ideal for parks, nature reserves, and coastal sites where weather resistance and environmental responsibility are key, delivering clear, accessible information with minimal impact on the surroundings.

Product features

- * Wood effect recycled plastic construction
- * 100% recyclable
- * No maintenance required
- * Tamper resistant fixings
- * Removable graphic panel
- * Standard sizes A3, A2, A1 and A0
- * 1 year manufacturer's warranty

Fitzpatrick Woolmer Design & Publishing Limited

Unit 7 Lakeside Park, Neptune Close, Rochester, Kent, ME2 4LT
t: 01634 711 771 e: info@fwdp.co.uk w: fwdp.co.uk



By Appointment to His Majesty The King
Manufacturer of Signs and Wayfinding
Fitzpatrick Woolmer Design & Publishing Ltd, Kent

Specification applies to the standard product. Our range of options usually allow us to accommodate any differences you may require. Please contact us and we will be happy to support you in developing this specification to meet your requirements.

Manufacturer: Fitzpatrick Woolmer,
Unit 7 Lakeside Park, Neptune Close,
Rochester, Kent, ME2 4LT.

Tel: 01634 711 771

Email: info@fwdp.co.uk

Material: Polystyrene foam

Origin: UK

Certification: 100% recycled plastic waste

Finish: Cedar effect

Visible fixings: Stainless steel security fixings to removable parts

Capacity: Will accommodate a 3mm thick printed graphic panel

Weight: 31kg

Installation: Wallmounting

Guarantee: One year manufacturer's warranty

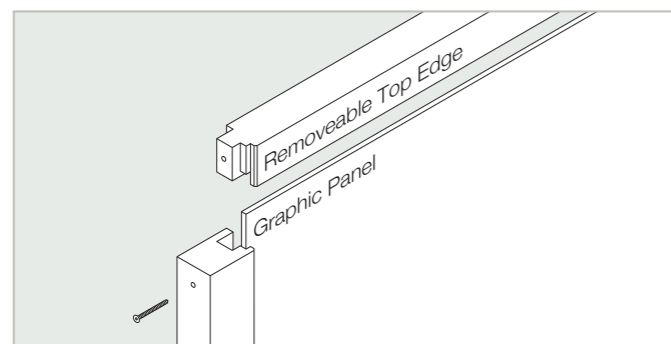

Standard frame assembly

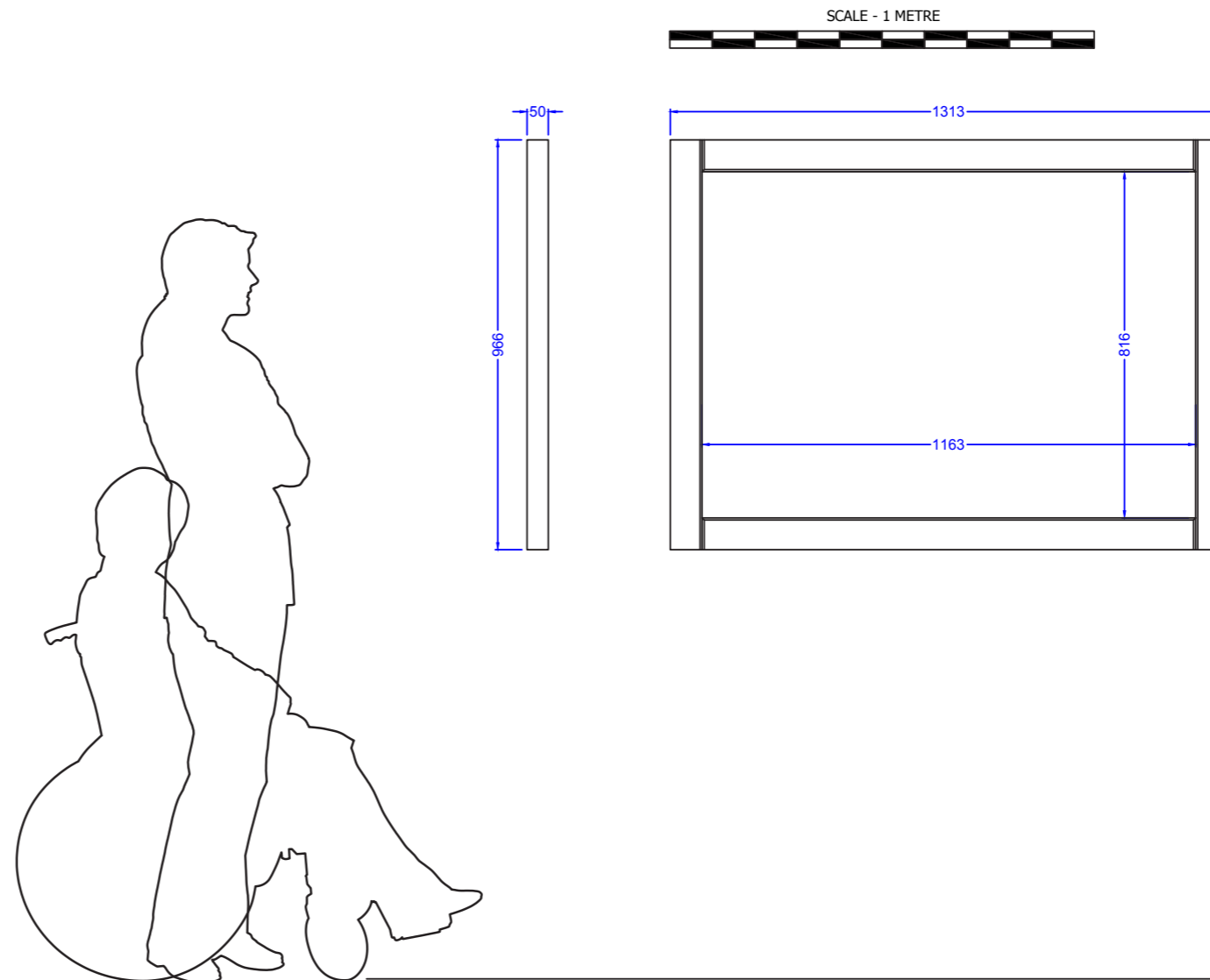

Note: All dimensions are indicative only. Footing details are subject to soil conditions and structural engineers recommendations.

Specification applies to the standard product. Our range of options usually allow us to accommodate any differences you may require. Please contact us and we will be happy to support you in developing this specification to meet your requirements.

Manufacturer: Fitzpatrick Woolmer,
Unit 7 Lakeside Park, Neptune Close,
Rochester, Kent, ME2 4LT.

Tel: 01634 711 771

Email: info@fwdp.co.uk

Material: Polystyrene foam

Origin: UK

Certification: 100% recycled plastic waste

Finish: Cedar effect

Visible fixings: Stainless steel security fixings to removable parts

Capacity: Will accommodate a 3mm thick printed graphic panel

Weight: 19kg

Installation: Wallmounting

Guarantee: One year manufacturer's warranty

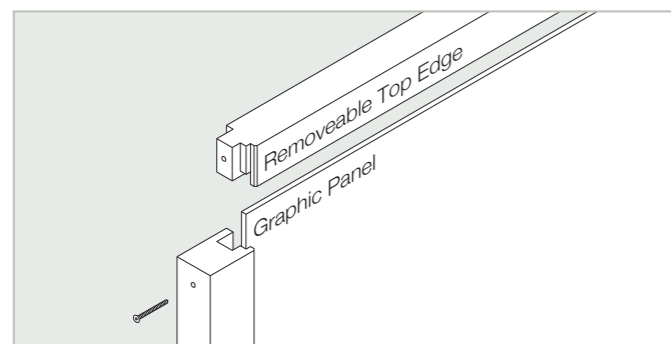

Standard frame assembly

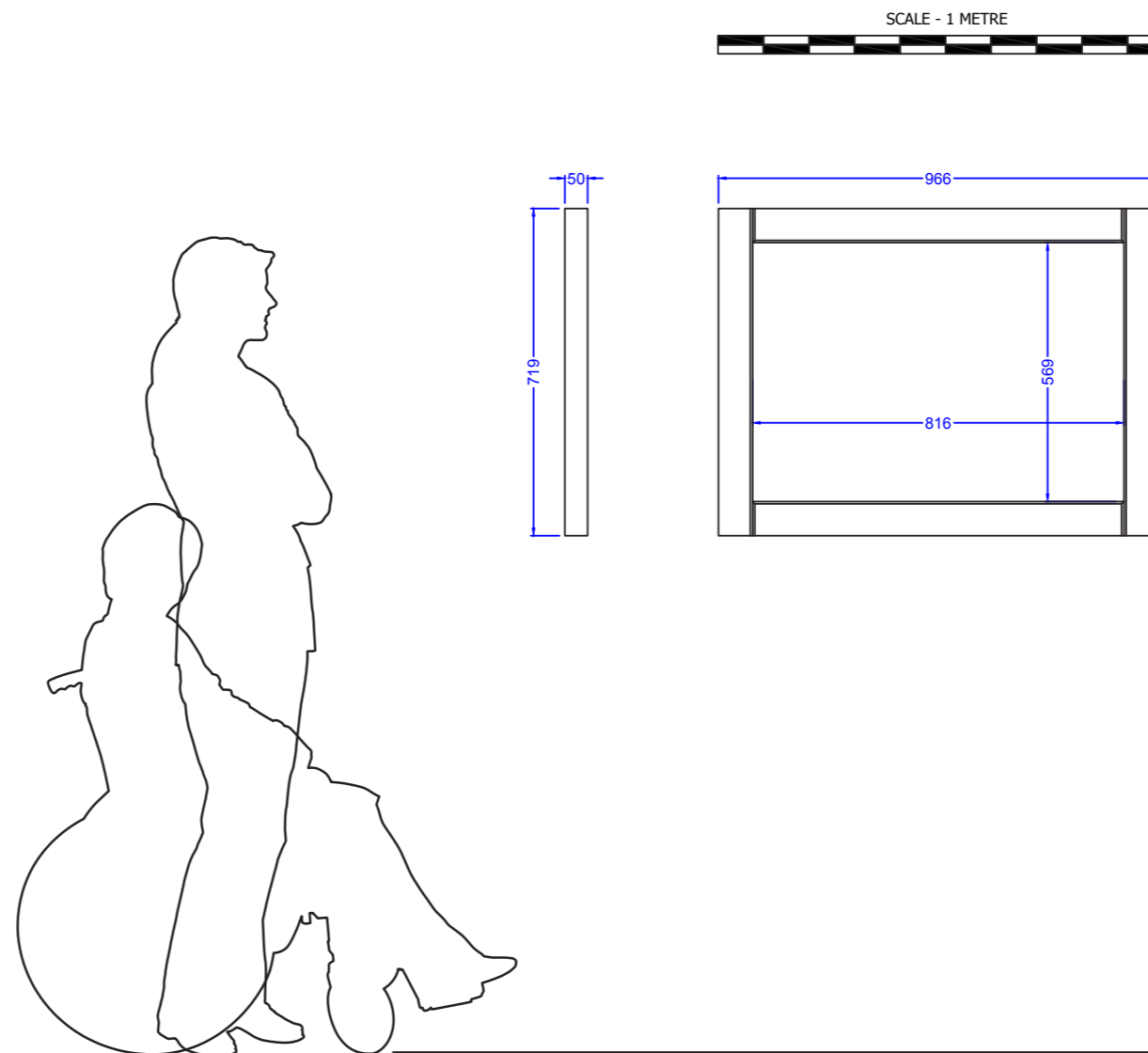

Note: All dimensions are indicative only. Footing details are subject to soil conditions and structural engineers recommendations.

Specification applies to the standard product. Our range of options usually allow us to accommodate any differences you may require. Please contact us and we will be happy to support you in developing this specification to meet your requirements.

Manufacturer: Fitzpatrick Woolmer,
Unit 7 Lakeside Park, Neptune Close,
Rochester, Kent, ME2 4LT.

Tel: 01634 711 771

Email: info@fwdp.co.uk

Material: Polystyrene foam

Origin: UK

Certification: 100% recycled plastic waste

Finish: Cedar effect

Visible fixings: Stainless steel security fixings to removable parts

Capacity: Will accommodate a 3mm thick printed graphic panel

Weight: 13kg

Installation: Wallmounting

Guarantee: One year manufacturer's warranty

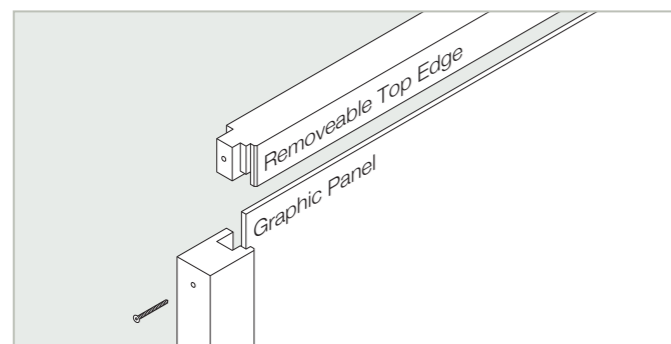

Standard frame assembly

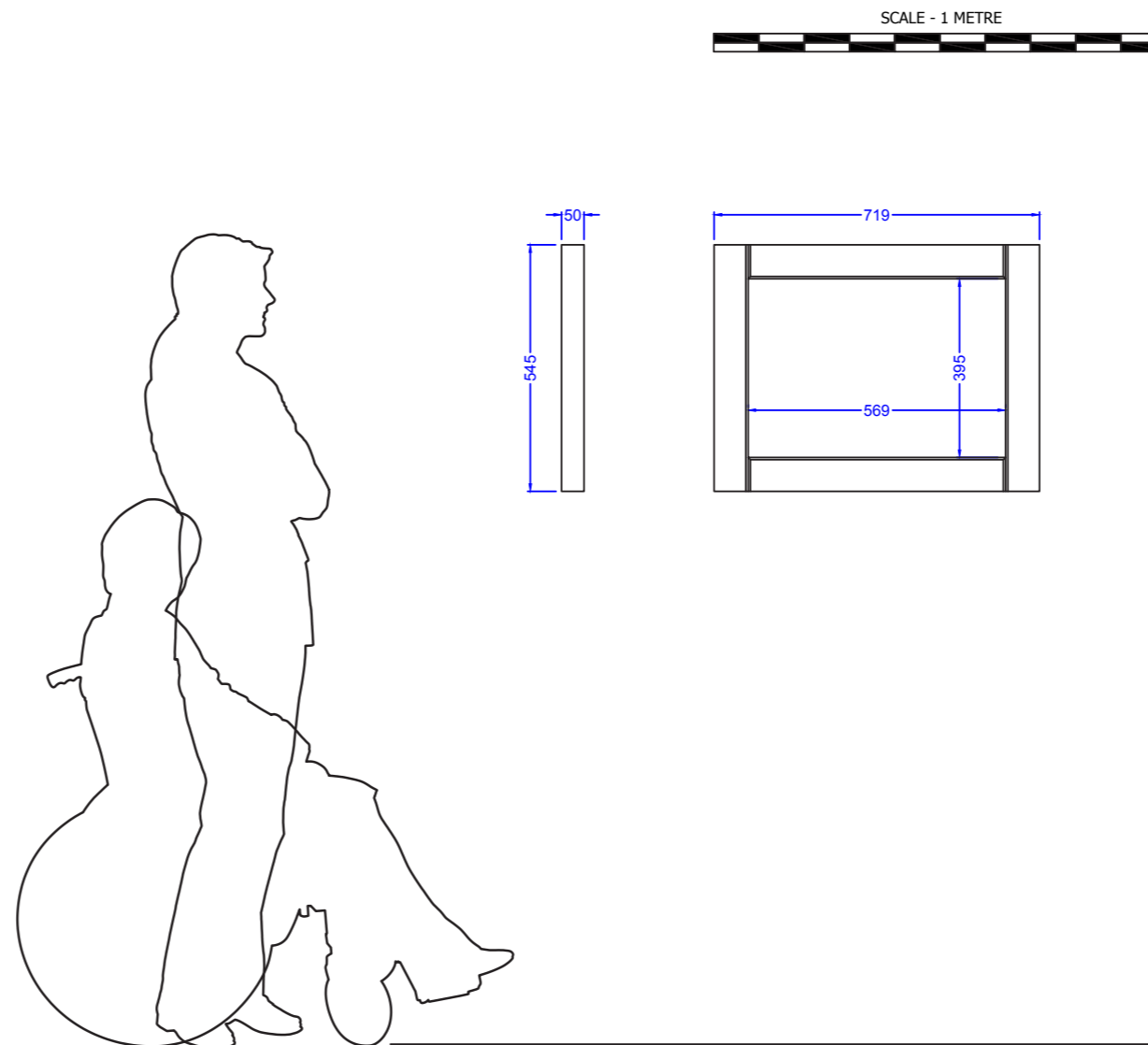

Note: All dimensions are indicative only. Footing details are subject to soil conditions and structural engineers recommendations.

Specification applies to the standard product. Our range of options usually allow us to accommodate any differences you may require. Please contact us and we will be happy to support you in developing this specification to meet your requirements.

Manufacturer: Fitzpatrick Woolmer,
Unit 7 Lakeside Park, Neptune Close,
Rochester, Kent, ME2 4LT.

Tel: 01634 711 771

Email: info@fwdp.co.uk

Material: Polystyrene foam

Origin: UK

Certification: 100% recycled plastic waste

Finish: Cedar effect

Visible fixings: Stainless steel security fixings to removable parts

Capacity: Will accommodate a 3mm thick printed graphic panel

Weight: 9kg

Installation: Wallmounting

Guarantee: One year manufacturer's warranty

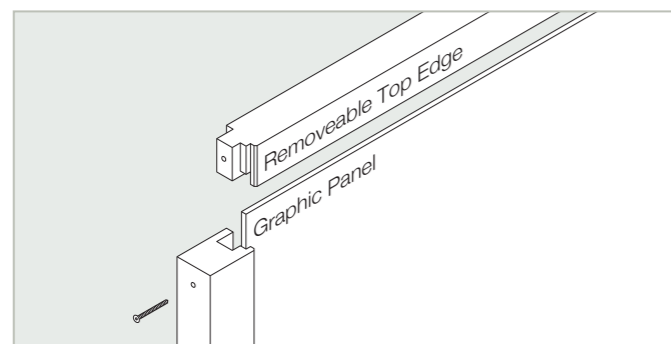

Standard frame assembly

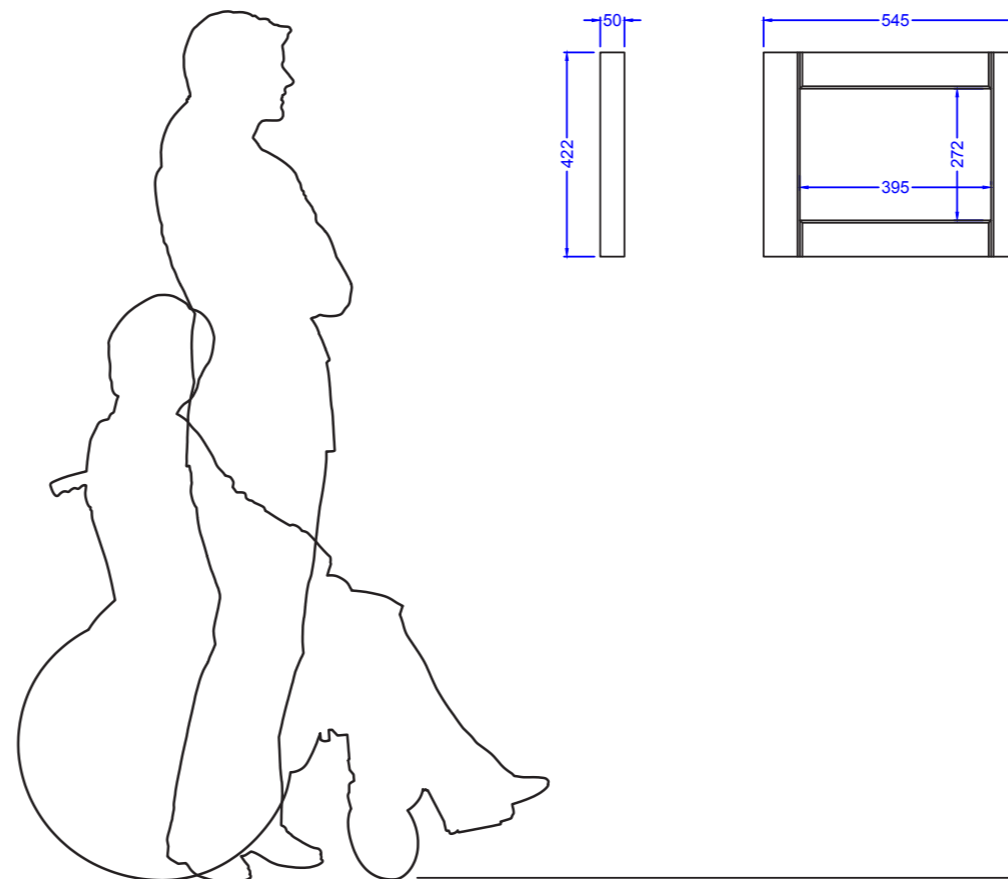
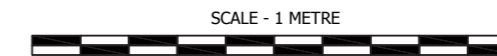

Note: All dimensions are indicative only. Footing details are subject to soil conditions and structural engineers recommendations.